

Quick Start Guide

Model 2900 System Manual



Thunder Scientific Corporation

Model 2900 Humidity Generation System

Document #SG2900 - Edition 2.5

Quick Start Guide

IMPORTANT NOTICE

DO NOT LOSE THIS FLYER

Go to this website to register your Model 2900 Humidity Generator and download your software for FREE.

https://www.thunderscientific.com/product_registration

Once you have registered your Model 2900 Humidity Generator, click the link on the same page, labeled [Click here if you need to download your FREE software.](#) 

Or go to this URL <https://www.thunderscientific.com/software/>

Next, click on which software type you need, and go to that page, then click the Download Now button.

After downloading your software, open the ZIP file and install your software.

This is a trusted download link form Thunder Scientific, Thank You for your purchase.

For:

HumiCalc[®] with Uncertainty Software Package Download

IMPORTANT CONTROL LOG PASSWORD INFORMATION

User: 2900

Manager: 2900.1

Administrator: Contact Thunder Scientific Technical Support
(1-800-872-7728 or support@thunderscientific.com)

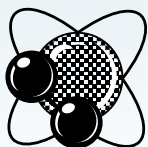

Humidity Generation and Calibration Equipment
THUNDER SCIENTIFIC[®]
CORPORATION The Humidity Source

Thunder Scientific Corporation
623 Wyoming Blvd SE
Albuquerque, NM 87123-3198
U. S. A.



Model 2900

www.thunderscientific.com

2900 Item Check List

1. Certificate of Calibration (In Chamber)

2. Quick Start Guide

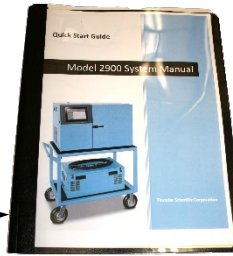

3. HumiCalc[®] with Uncertainty Software Download



4. Chamber Port Plugs



5. Keyboard



6. Power Cable



7. Torx Driver with Screws



8. Reservoir Fluid Funnel



9. Chamber Fill Funnel



10. Plugs, 1/4 Swagelok



11. Elbow, 1/4 Tube x 1/4 NPT



12. Communication Cable (DB9)



13. USB Serial Converter



14. Display Cleaning Cloth



15. Stylus Pen



16. Plastic Beaker 1000ML



17. 3/8" Plastic Elec Flex Conduit 36"



18. Velcro Straps 2 Ea.



19. Temp Probe or UT Cap Tool



20. Chamber Fluid

70% PROPYLENE GLYCOL 2 bottles for your system



1. **Optional Equipment** – Air Compressor Power Cable

2. **ACS2520** – Air Compressor System Manual

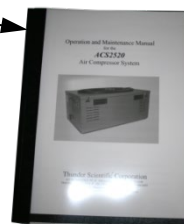

3. **Air Hose** – On Air Box



4. **ACS Remote Control Cable**



Suomi

Tämä tuote noudattaa WEEE-direktiivin (2002/96/EY) merkintävaatimuksia. Kiinnitetty etiketti osoittaa, että tätä sähkö-/elektroniikkalaitetta ei saa hävittää kotitalousjätteissä.

Tuoteluokka: Viitaten WEEE-direktiivin liitteessä I mainittuihin laitteisiin, tämä tuote on luokiteltu luokan 9 "Tarkkailu- ja ohjauslaitteet" -tuotteeksi.



Ei saa heittää kotitalousjätteiden mukana!

Palauta tarpeettomat tuotteet ottamalla yhteyttä valmistajan websivustoon, joka mainitaan tuotteessa tai paikalliseen myyntitoimistoon tai jakelijaan.

Dansk

Dette produkt er i overensstemmelse med kravene om afmærkning i WEEE-direktivet (2002/96/EC). Det påhæftede mærkat angiver, at du ikke må bortskaffe dette elektriske/elektroniske produkt via husholdningsaffald.

Produktkategori: Med reference til kravene i WEEE-direktivets bilag I klassificeres dette produkt som et produkt til "overvågning og kontrolinstrumentering" i kategori 9.



MÅ ikke bortskaffes via husholdningsaffald!

Hvis du vil returnere uønskede produkter, skal du besøge producentens websted, som vises på produktet, eller den lokale forhandler eller distributør.

English

This product complies with the WEEE Directive (2002/96/EC) marking requirements. The affixed label indicates that you must not discard this electrical/electronic product in domestic household waste.

Product Category: With reference to the equipment types in the WEEE Directive Annex I, this product is classed as category 9 "Monitoring and Control Instrumentation" product.



Do not dispose in domestic household waste!

To return unwanted products, contact the manufacturer's web site shown on the product or your local sales office or distributor.

Français

Ce produit est conforme aux normes de marquage de la directive DEEE (2002/96/CE). La présence de cette étiquette indique que cet appareil électrique/électronique ne doit pas être mis au rebut avec les déchets ménagers.

Catégorie de DEEE : Cet appareil est classé comme catégorie 9 parmi les « instruments de surveillance et de contrôle » en référence aux types d'équipements mentionnés dans l'Annexe I de la directive DEEE.



Ne pas éliminer avec les autres déchets ménagers !

Pour renvoyer les produits indésirables, contacter le site Web du fabricant mentionné sur le produit, ou son distributeur ou bureau de ventes local.

Español

Este producto cumple la Directiva WEEE (2002/96/EC) sobre requisitos de las marcas. La etiqueta que lleva pegada indica que no debe desechar este producto eléctrico o electrónico con los residuos domésticos.

Categoría del producto: con referencia a los tipos de equipo del anexo I de la Directiva WEEE, este producto está clasificado como categoría 9 de "Instrumentación de supervisión y control".



¡No lo deseche con los residuos domésticos!

Para devolver productos que no desee, póngase en contacto con el sitio Web del fabricante mostrado en el producto, o con la oficina de ventas o distribuidor local.

Deutsch

Dieses Produkt stimmt mit den Kennzeichnungsanforderungen der WEEE-Richtlinie (2002/96/EC) überein. Das angebrachte Etikett weist darauf hin, dass dieses elektrische/elektronische Produkt nicht in Hausmüll entsorgt werden darf.

Produktkategorie: In Bezug auf die Gerätetypen in Anhang I der WEEE-Richtlinie ist dieses Produkt als Kategorie 9 "Überwachungs- und Kontrollinstrument" klassifiziert.



Nicht in Hausmüll entsorgen!

Zur Rückgabe von unerwünschten Produkten die auf dem Produkt angegebene Website des Herstellers oder die zuständige Verkaufsstelle bzw. den zuständigen Fachhändler konsultieren.

Italiano

Questo prodotto risponde ai requisiti sull'etichettatura stabiliti nella Direttiva RAEE (2002/96/CE). Il simbolo apposto indica che non si deve gettare questo prodotto elettrico o elettronico in un contenitore per rifiuti domestici.

Categoria del prodotto: con riferimento ai tipi di apparecchiature elencate nell'Allegato 1 della Direttiva RAEE, questo prodotto rientra nella categoria 9 "Strumenti di monitoraggio e di controllo".



Non gettare in un contenitore per rifiuti domestici.

Per restituire prodotti non desiderati, visitare il sito Web del produttore riportato sul prodotto o rivolgersi al distributore o all'ufficio vendite locale.

Português

Este produto está em conformidade com as exigências de rotulagem da Directiva WEEE (2002/96/EC). O rótulo afixado indica que o utilizador não deve deitar este produto eléctrico/electrónico fora juntamente com o lixo doméstico.

Categoria do produto: No que se refere aos tipos de equipamento listados no Anexo I da Directiva WEEE, este produto está classificado como produto da categoria 9, "Instrumentação de monitorização e controlo".



Não deite fora juntamente com o lixo doméstico!

Para devolver produtos indesejados, contacte o fabricante através do Website constante do produto ou contacte o seu representante de vendas ou distribuidor local.

Nederlands

Dit product voldoet aan de merktekenvereisten van de AEEA-richtlijn (2002/96/EG). Het aangebrachte merkteken duidt erop dat dit elektrische/elektronische product niet met het huishoudelijk afval mag worden afgevoerd.

Productcategorie: Met betrekking tot de apparatuurcategorieën van bijlage I van de AEEA-richtlijn, valt dit product onder categorie 9 'meet- en controle-instrumenten'.



Niet afvoeren met huishoudelijk afval!

Om ongewenste producten te retourneren, neemt u contact op met de website van de fabrikant die op het product staat vermeld, of met uw plaatselijke verkoopkantoor of distributeur.

Svenska

Denna produkt uppfyller märkningskraven enligt WEEE Directive (2002/96/EC). Märkningsetiketten anger att du inte får kassera denna elektriska/elektroniska produkt tillsammans med vanliga hushållssopor.

Produktkategori: Med hänvisning till utrustningstyperna i WEEE Directive Annex I, är denna produkt klassad som kategori 9 "Monitoring and Control Instrumentation" (Instrument för övervakning och styrning).



Får ej kasseras tillsammans med vanliga hushållssopor!

Returnera ej önskvärda produkter genom att gå till tillverkarens webbplats, vilken anges på produkten, eller till det lokala försäljningskontoret eller distributören.

Norsk

Dette produktet oppfyller bestemmelsene ifølge WEEE-direktiv (2002/96/EC) med krav til merking. Påsatt merke viser at det ikke er tillatt å kassere dette elektriske/elektroniske produktet sammen med husholdningsavfall.

Produktkategori: På grunnlag av utstyrstypene i WEEE-direktivet, vedlegg I, er dette produktet klassifisert i kategori 9, "Instrumentering for overvåking og kontroll".



Må ikke kastes sammen med husholdningsavfall!

Ved behov for returforsendelse av uønskede produkter må du gå til produsentens nettside som er angitt på produktet, eller du må kontakte det lokale salgskontoret eller den lokale forhandleren.

Quick Start Guide

For full version of this manual click on the Help Menu located on the upper right corner of the screen

Or go to www.thunderscientific.com/reference_manuals

1 CONTENTS

2	Getting Started	2
2.1	About.....	2
2.2	Notice	3
2.3	Safety Information.....	3
2.3.1	Personal Protective Equipment (PPE).....	6
2.3.2	Lifting and Carrying.....	6
2.4	Technical Support.....	6
2.5	License Agreement.....	6
2.6	Warranty	8
2.7	Copyright.....	8
2.8	Trademarks.....	8
2.9	Specifications	9
2.9.1	I/O Ports	10
2.10	Uncertainty	10
2.11	Facility Requirements.....	11
2.11.1	Environment.....	11
2.11.2	Floor Space	11
2.11.3	Power	11
2.11.4	Air Supply	11
2.11.5	Distilled Water Supply	11
2.11.6	Storage	11
2.12	Installation.....	12
2.12.1	Uncrating.....	12
2.12.2	Positioning	12
2.12.3	Chamber Fluid.....	12
2.12.4	Reservoir Initial Filling Procedure	14
2.12.5	Setting Supply Pressure Regulator	14
2.13	Quick Start.....	15
2.13.1	Power-Up	15
2.13.2	Loading Screen.....	16
2.13.3	ControLog Screen	17
2.13.4	Control Parameters.....	18
2.13.5	Control Modes.....	20
2.13.6	Generating and Shutting down.....	21
2.13.7	Power-Off.....	22
2.13.8	Set Date and Time	23
2.13.9	Help.....	24
Reference Drawings	18D29901-2,3 &4 + 18D29909-1, 2	

2 GETTING STARTED

This section will provide the user with information about the Model 2900 humidity generator, where to obtain technical support, software license agreement, specifications, uncertainty, facility requirements and installation. Following sections will provide further details on how to use and operate the Model 2900 generator using the ControLog® software.

Note - *All pressures are absolute unless noted otherwise.*

2.1 ABOUT

The Thunder Scientific Model 2900 Humidity Generator is capable of producing known humidity values using the fundamental, NIST proven, "two-pressure" principle. The Model 2900 uses this fundamental "two-pressure" principle to continuously supply a known relative humidity, dew point, frost point, parts per million, or other calculated value for instrument calibration and evaluation as well as precision environmental testing.

The Model 2900 humidity generator encompasses a high-performance stand-alone Data Acquisition Computer that performs all functions required for humidity generation and control and a second dedicated Human Machine Interface (HMI) computer that runs ControLog. ControLog is a software application that fully automates the operation of the Model 2900 humidity generator and allows various device connections through a number of different interfaces. Data from the generator and connected device or devices is automatically retrieved and stored for viewing in either numerical or graphical format in real time or post process. Data can be transferred off the system via a USB drive for further viewing, post processing and printing. The ControLog software also provides the primary interface to the operator via the multi-point touch LCD and keyboard.

Key features of the ControLog software are:

- ControLog stores data into individual data sheets (tab). Each data sheet contains a spreadsheet type view that consists of a date/time stamp and the measured data items corresponding to that date/time stamp. Data sheets consist of three similar but different types: Device Data, File Data and Data Summary. Each type has the same spreadsheet type view and operation, but all three have different data sources.
- Graphing is a powerful tool used to view previously recorded data or to monitor the current data in real-time. The graph works hand in hand with the data sheets. While the generator is in operation, data sheets store the most recent data points from the generator and or connected devices at the desired interval. A graph can be used to create a visual picture of this stored data.
- The Auto Profiling feature is very similar to the Generate mode with the main exception that profiling relies on a predefined list of setpoints referred to as a profile. The user configurable profile is used as ControLog's road map during Auto Profile operation. It defines which setpoint values to go to, at what rate to go from one setpoint to another, and how long to stay at a specific setpoint before moving to the next setpoint.
- ControLog supports a customizable interface that works with most devices. ControLog will allow the user to create a new device connection using the "Connection Wizard" or open previously saved connections. The wizard will open a separate dialog window containing

various steps that will guide the user in defining the communication required to receive the desired data items from the device. The user can create as many (up to 60) or as few data items as they see fit for any one device. Each data item can be uniquely named and once connected will be recorded in its own data sheet. ControLog also allows the user to save these interfaces for future use. The "Connection Wizard" allows the user to step through the connection configuration. Using the "Next" and "Back" buttons the user is allowed to progress through the connection configuration steps. At any time, the user may cancel the new connection or opening of a connection by selecting the "Cancel" button. Once the last step has been completed the "Finish" button will be available to complete the new connection.

2.2 NOTICE

The specifications listed and the information contained in this document is subject to change without notice. Screen shots shown in this document may differ slightly from the actual product and are given to show functionality of the examples, procedures and program. Thunder Scientific Corporation makes no warranties, either express or implied, regarding the examples, procedures and program, or the fitness of these examples, procedures or program for a particular purpose. The examples, procedures and program are made available solely on an "as is" basis and the entire risk as to their quality and performance rests with the user. Thunder Scientific Corporation shall not be liable for any incidental or consequential damages in connection with or arising out of the furnishing, use, or performance of the examples, procedures or program.

2.3 SAFETY INFORMATION

Important safety guidelines need to be observed when operating this equipment. Precautions are highly advisable so that no personal injury will occur during the operation and maintenance of the system. Observation of local and national regulations must be adhered to regarding safety standards.

FCC Statement

Note: This equipment has been tested and found to comply with the limits for a Class A digital device, pursuant to part 15 of the FCC Rules. These limits are designed to provide reasonable protection against harmful interference when the equipment is operated in a commercial environment. This equipment generates, uses, and can radiate radio frequency energy and, if not installed and used in accordance with the instruction manual, may cause harmful interference to radio communications. Operation of this equipment in a residential area is likely to cause harmful interference in which case the user will be required to correct the interference at his own expense.

Symbols

The symbols used in the manuals and on the Product are shown below in table 1-1.

Warning indicates a potential hazard may exist and the user should be extremely careful.

Caution! identifies a condition or action that may cause damage to the system or the user.







Symbol	Description
	This symbol is shown from the WEEE directive and indicates do not dispose of this product in any municipal waste area.
	This symbol means Caution and should be observed or important information.
	This symbol indicates a potential shock hazard may exist.
	This symbol means Earth Ground.
	This symbol denotes Heat or Hot Surface, or Gases.
	This symbol signifies Carefully read all instructions.
	See FCC Statement above.

Table 1-1

 **Warning!**

To prevent possible electrical shock, fire, or personal injury:

- Carefully read all instructions.
- Read all safety information before using the Product.
- Read and understand the safety data sheet (SDS) supplied with the purchased methanol and take necessary precautions.
- Use this Product indoors only.
- Position the Product so that the main power cord is always accessible.
- Replace the power cord if the insulation is damaged or shows signs of wear.
NOTE: The power cord is a safety-critical component. The user must not replace the power cord with an inadequately rated alternative.
- Do not use an extension cord or adapter plug.
- Do not alter the Product. Use only as specified, or the Product's protection features can be compromised.
- Do not use the Product if it is altered or damaged.
- Do not use the Product around explosive gas, vapor, or in damp/wet environments.
- Ensure the power cord's ground conductor is connected to a protective earth ground. Disruption of the protective earth ground could put lethal voltage on the Product's chassis.
- Ensure the space around the Product meets minimum requirements.
- Use only specified replacement parts.
- Ensure only trained personnel perform repairs to the Product.

- Do not operate the Product with electrical cover removed. Exposure to Hazardous voltage is possible.

 **Warning: High Pressure**

- High pressure gases are potentially hazardous. Energy stored in these gases can be released suddenly and with extreme force. Proper safety precautions must be taken when applying any pressure to the Product. Before applying pressure to the Product, ensure all pneumatic connections are properly secured and tightened. Ensure all pressure settings are set to the proper values before operation, testing, calibration or maintenance is performed.
- POSSIBLE INJURY! The tubing, valves, and other apparatus attached to the Product must be adequate for the maximum applied pressure, otherwise, physical injury to the operator or bystanders is possible.
- USE THE PROPER PRESSURE MEDIUM! Use only clean, dry, gaseous nitrogen or CO2-free air unless otherwise specified by Thunder Scientific.

 **Warning: This Product contains 16 oz. of R-134a refrigerant**

R-134a EMERGENCY OVERVIEW: Colorless, volatile liquid with an ethereal and faint sweetish odor. Non-flammable material. Overexposure may cause dizziness and loss of concentration. At higher exposure levels, CNS depression and cardiac arrhythmia may occur. In confined spaces, vapors displace air and can cause asphyxiation. At higher temperatures, (>250°C), decomposition will occur resulting in the possible production of Hydrofluoric Acid (HF) and carbonyl halides.

 **WARNING: R-134a POTENTIAL HEALTH HAZARDS**

- SKIN: Irritation would result from a defatting action on tissue. Liquid contact could cause frostbite.
- EYES: Liquid contact can cause severe irritation and frostbite. Mist may irritate.
- INHALATION: R-134a is low in acute toxicity in animals. When oxygen levels in air are reduced to 12-14% by displacement, symptoms of asphyxiation, loss of coordination, increased pulse rate and deeper respiration will occur. At high levels, cardiac arrhythmia may occur.
- INGESTION: Ingestion is unlikely because of the low boiling point of the material. Should it occur, discomfort in the gastrointestinal tract from rapid evaporation of the material and consequent evolution of gas would result. Some effects of inhalation and skin exposure would be expected.

 **Caution: Electrostatic Discharge**

Electrostatic discharge (ESD) could possibly damage or destroy solid-state parts when exposed to static electric discharges. Be aware because electrostatic discharges may not be seen, felt or heard at levels less than 4,000 volts.

THE TERMS SET FORTH HERE. PLEASE READ THIS LICENSE AGREEMENT. IF YOU DO NOT AGREE TO THESE TERMS, RETURN THE FULL PRODUCT WITH PROOF OF PURCHASE WITHIN 30 DAYS FOR A FULL REFUND.

- **GRANT OF LICENSE.** TSC grants to you the right to use one copy of the enclosed SOFTWARE on a single terminal connected to a single computer (i.e. single CPU) or to a network server. If you install the SOFTWARE on a network server, you must purchase a separate copy of the SOFTWARE for each computer terminal that will be used to operate the SOFTWARE. If the anticipated number of users of the SOFTWARE will exceed the number of applicable Licenses, then you must have a reasonable mechanism in place to ensure that the number of persons using the SOFTWARE concurrently does not exceed the number of Licenses. If the SOFTWARE is permanently installed on the hard disk or other storage device of a computer (other than a network server) and one person uses that computer more than 80% of the time, then that person may also use the SOFTWARE on a portable or home computer.
- **COPYRIGHT.** The SOFTWARE is owned by TSC and is protected by United States copyright laws and international treaty provisions. You may either (a) make two copies of the SOFTWARE solely for backup or archival purposes provided that you reproduce all copyright and other proprietary notices that are on the original copy of the SOFTWARE provided to you, or (b) transfer the SOFTWARE to a single hard disk provided you keep the original solely for backup or archival purpose. You may not copy the written materials accompanying the SOFTWARE.
- **OTHER RESTRICTIONS.** You may not rent or lease the SOFTWARE, but you may transfer the SOFTWARE and accompanying written materials on a permanent basis provided you retain no copies and the recipient agrees to the terms of this Agreement. You may not reverse engineer, decompile, disassemble, or create derivative works from the SOFTWARE.

SOFTWARE and written materials

- **GOVERNMENT LICENSEE.** If you are acquiring the SOFTWARE on behalf of any unit or agency of the United States Government, the following provisions apply:

The Government acknowledges TSC's representation that the SOFTWARE and its documentation were developed at private expense and no part of them is in the public domain.

The Government acknowledges TSC's representation that the SOFTWARE is "Restricted Computer Software" as that term is defined in Clause 52.227-19 of the Federal Acquisition Regulations (FAR) and is "Commercial Computer Software" as that term is defined in Subpart 227.471 of the Department of Defense Federal Acquisition Regulations Supplement (DFARS).

The Government agrees that:

(i) If the SOFTWARE is supplied to the Department of Defense (DoD), the SOFTWARE is classified as "Commercial Computer Software" and the Government is acquiring only "restricted rights" in the SOFTWARE and its documentation as that term is defined in Clause 252.227-7013(c) (1) of the DFARS, and

(ii) If the SOFTWARE is supplied to any unit or agency of the United States Government other than DoD, the Government's rights in the SOFTWARE and its documentation will be as defined in Clause 52.227-19 (c) (2) of the FAR.

- **RESTRICTED RIGHTS LEGEND.** Use, duplication, or disclosure by the Government is subject to restrictions as set forth in subparagraph (c) (1) (ii) of the Rights in Technical Data and Computer Software clause at DFARS 252.227-7013. Thunder Scientific Corporation, 623 Wyoming SE, Albuquerque, NM 87123.
- **EXPORT LAW ASSURANCES.** You acknowledge and agree that the SOFTWARE is subject to restrictions and controls imposed by the United States Export Administration Act (the "Act") and the regulations thereunder. You agree and certify that neither the SOFTWARE nor any direct product thereof is being or will be acquired, shipped, transferred or re-exported, directly or indirectly, into any country prohibited by the Act and the regulations thereunder or will be used for any purpose prohibited by the same.
- **GENERAL.** This Agreement will be governed by the laws of the State of New Mexico, except for that body of law dealing with conflicts of law.

Should you have any questions concerning this Agreement, or if you desire to contact TSC for any reason, please write: Thunder Scientific Corporation, 623 Wyoming NE, Albuquerque, NM 87123

2.6 WARRANTY

Thunder Scientific Corporation (TSC) warrants, to the Buyer, the Product manufactured by TSC to be free of defects in material and workmanship under normal use and service and to be free from inadequate mechanical design when operated within the specified design limitations for a period of one year from date of acceptance. TSC's obligation under this warranty shall be limited to the following: The Product is returned to TSC with transportation charges prepaid and that TSC's examination reveals the Product to be defective. TSC, at its option, shall either refund to the Buyer the purchase price of the product or repair or replace at TSC's plant, any part or parts of the Product which is or are defective. This warranty shall not apply to any Product which has been maintained, handled, stored, repaired or altered in any manner, or by anyone other than an authorized TSC representative, so as to affect adversely such Product or which has been subject to improper installation, misuse, negligence, accident or corrosion. THIS WARRANTY IS EXCLUSIVE AND IN LIEU OF ANY WARRANTY OF MERCHANTABILITY, FITNESS FOR A PARTICULAR PURPOSE OR ANY OTHER WARRANTY, WHETHER EXPRESS OR IMPLIED, AND ALL OTHER LIABILITIES AND OBLIGATIONS ON THE PART OF TSC; TSC SHALL NOT BE LIABLE FOR ANY OTHER CLAIMS OR DAMAGES, EITHER DIRECT OR CONSEQUENTIAL, ARISING DIRECTLY OR INDIRECTLY OUT OF SUPPLYING THE PRODUCT. All warranties, express or implied, with respect to any device or component not manufactured by TSC but incorporated into its Product are the responsibility of the original manufacturer and shall not affect or apply to TSC.

2.7 COPYRIGHT

©2009-2026 Thunder Scientific Corporation

623 Wyoming Blvd. SE

Albuquerque, New Mexico 87123, USA

This document contains proprietary information which is protected by copyright. All rights are reserved. No part of this document may be reproduced or transmitted in any form or by any means, electronic or mechanical, including photocopying and recording, for any purpose without the prior written consent of Thunder Scientific Corporation.

2.8 TRADEMARKS

® *ControLog* is a trademark of Thunder Scientific Corporation.

® *HumiCalc* is a trademark of Thunder Scientific Corporation.

® THUNDER SCIENTIFIC is the registered trademark of Thunder Scientific Corporation

MADE IN USA



Microsoft Software License Terms

Last updated April 2024

Follow this link to view Microsoft's Software License Terms or scan this QR code to download your copy.

<https://learn.microsoft.com/en-us/windows/iot/iot-enterprise/eula/end-user-license-agreement>

© Microsoft Corporation 2025 - <https://www.microsoft.com/en-us/>



2.9 SPECIFICATIONS¹

Relative Humidity Range:	10 to 95 %RH, 10 to 40 L/min
Relative Humidity Range: ²	95 to 98 %RH, 10 to 20 L/min
Frost Point Temperature Range:	-33.60 to 0 °C
Dew Point Temperature Range:	-36.94 to 70 °C
Chamber Fluid Temperature Range: ³	-10 to 72 °C
Chamber Fluid Temperature Control Stability: ⁴	0.002 °C
Chamber Fluid Temperature Uniformity: ⁵	<0.04 °C
Chamber Fluid Temperature Heating Rate: from -10 to 72 °C	0.5 °C per Minute (average)
Chamber Fluid Temperature Cooling Rate: from 72 to 10 °C	0.5 °C per Minute (average)
Chamber Fluid Temperature Cooling Rate: from 10 to -10 °C	0.2 °C per Minute (average)
Temperature Specification:	0.027 °C
Gas Type:	Air or Nitrogen
Gas Pressure Rating: (MAWP)	165 psiG
Gas Flow Rate Range:	10 to 50 L/min
Gas Flow Rate Specification:	5% of full scale
Saturation Pressure Range:	Ambient to 160 psiA
Saturation Pressure Specification:	0.02% of full scale
Test Chamber Pressure Range:	Ambient
Test Chamber Pressure Specification:	0.0034 psiA
Supply Pressure Range: ⁶	75 to 150 psiG
Supply Pressure Specification:	±1 psiG
Display Resolution:	0.001
Test Chamber Dimensions:	12" x 12" x 10" (304.8 mm x 304.8 mm x 254 mm)
Maximum Load:	44 Lbs. (19.9 Kg) Equally distributed in chamber
Physical Dimensions:	22" H x 36" W x 23" D (558.8 mm x 432 mm x 584.2 mm)
Physical Dimensions (on Cart):	56.7" H x 44.4" W x 26" D (1440 mm x 1128 mm x 661 mm)
Weight: (Generator Only)	265 Lbs. (120.2 Kg)
Weight: (Generator, Cart & Air System)	521 Lbs. (236.3 Kg)

1 Test pressure at 1 atmosphere.

2 The system will limit mass flow rate to 20 L/min for %RH greater than 95.

3 Only the glycol/water heat transfer fluid circulating around the chamber is controlled to setpoint. Chamber temperature inside the chamber may vary depending on door configuration, setup, and uniformity. Note: the 2900 can only operate for a finite amount of time at or below 0 °C

4 Temperature Control Stability is defined as the standard deviation over a 10-minute period, as measured by the saturation temperature control sensor after being at point for 60 minutes.

5 Chamber Temperature Uniformity is defined as the maximum temperature difference between any two locations at a single point in time. Locations are within one inch of the chamber wall and within 2.5 inches of the chamber door. Using a minimum chamber fan speed of 25% for a temperature range of -10 °C to 72 ° when using fluid jacket door option and ±10 °C from ambient when not.

6 Regulated supply pressure lower than the recommended is acceptable but will limit the lowest humidity obtainable from the generator and will require an internal pressure regulator (REG) adjustment.

2.9.1 I/O Ports

USB Ports: 2 x USB 3.0
Serial Port:..... 1 x RS-232 COM

2.10 UNCERTAINTY ⁷

RH Uncertainty: 10 to 95 %RH, 0 to 70 °C, 10 to 40 L/min0.5% of reading
RH Uncertainty: 95 to 98 %RH, 0 to 70 °C, 10 to 20 L/min0.5% of reading
Dew/Frost Point Uncertainty: < 0 °C, 10 to 40 L/min 0.05 °C
Dew Point Uncertainty: 0 to 70 °C, 10 to 40 L/min..... 0.08 °C
Temperature Uncertainty: -10 to 72 °C 0.031 °C
Chamber Pressure: Ambient..... 0.007 psiA

⁷ Chamber pressure at 1 atmosphere, Uncertainty values represent an expanded uncertainty using a coverage factor, k=2, at an approximate level of confidence of 95%. Uncertainty is not specified at saturation temperatures below 0 °C or at flow rates below 10 L/min. Uncertainty is based on the worst-case value from the 2900 uncertainty analysis.

2.11 FACILITY REQUIREMENTS

2.11.1 Environment

Operating Temperature:	15 to 30 °C
Storage Temperature:	5 to 50 °C
Humidity:	5 to 90% RH Non-condensing
Pollution Degree:	PD2
Maximum Operating Altitude:	7600 Feet

2.11.2 Floor Space

A bench and/or floor, capable of supporting approximately 310 pounds, with a minimum space of 27" (0.686m) deep x 43" (1.09m) wide.

Allow an additional 20" (0.508m) in width for clearance, if possible, to allow complete opening of the chamber door and access to the test ports.



Caution: Ensure wheel locks are engaged whenever the cart is stationary.

Refer to drawings: [18D29901-2](#), [18D29910-1](#)

2.11.3 Power

Electrical Power:	230 V~ (±10 %), 10 A, 1 ϕ , 50 Hz or 60 Hz
Overvoltage:	CAT II

2.11.4 Air Supply

When not using the pneumatic cart, a clean, oil free instrument air supply operating at 165 psiG and 50 L/m is required. The air supply should be filtered to a particle size of 0.5 microns or less, a hydrocarbon content of 1 PPM or less, with a pressure dewpoint of 15 °C or less. Regulated supply pressure other than recommended (175 psiG maximum) is acceptable but may limit the lowest humidity obtainable from the generator and will require an internal pressure regulator (REG) adjustment.

Refer to section [2.12.5 Setting Supply Pressure Regulator](#) for more information on adjusting the internal pressure regulator (REG).

2.11.5 Distilled Water Supply

One gallon (3.8 liters) of double distilled water per fill. The one-gallon supply can last from 8 hours to more than 500 hours of use depending upon the temperature and humidity at which the generator is operated (reference section [13.3.4](#)). During operation near ambient temperature and 50% RH, one gallon should last for approximately 200 hours.

2.11.6 Storage

The following are required when the system is put into storage or is transported.

- Disconnect the supply and outlet lines.

- Seal all inlet and outlet ports.
- Drain the chamber following section 2.12.3 Chamber Fluid Draining Procedure

Storage Environment

- Storage Temperature: 5 to 50 °C (empty)
- Humidity: 5 to 95% RH Non-condensing

2.12 INSTALLATION

2.12.1 Uncrating

Before uncrating, carefully inspect the crate and skid to be certain the unit was not subjected to damage. If there is damage, proceed no further and notify your inspection department and the shipping agent.

If the crate appears satisfactory:

1. Remove steel strapping.
2. Using "Clip Removal Tool" or thin pry-bar, remove top cover clips then remove top panel.
3. One panel at a time, remove the panel clips then remove panel.
4. Remove polyethylene covering from unit.
5. Inspect for any visible damage.
6. Remove any/all accessory boxes.
7. Using forklift or another suitable lifting device, lift unit from skid and place on the 2900 cart or instrument bench.

CAUTION!

BEFORE APPROACHING THE EQUIPMENT WITH THE FORKLIFT, VISUALLY LOCATE ANY HARDWARE WHICH MIGHT PROJECT INTO THE PATH OF THE FORKS. PLACE FORKS AS WIDE AS POSSIBLE TO AVOID DAMAGE TO THE FRAME.

8. The unit may now be rolled to its point of installation.

2.12.2 Positioning

Position the system to have access to all sides of the console. Remove cover panels and inspect for any visible damage that might have occurred during shipment.

CAUTION!

ALWAYS USE THE FILE>TURN OFF COMMAND TO PROPERLY EXIT THE SOFTWARE AND SHUTDOWN THE COMPUTERS SO THAT THE MAIN POWER SWITCH CAN BE SWITCHED OFF.

2.12.3 Chamber Fluid

Temperature conditioning of the Model 2900 test chamber utilizes a mixture of propylene glycol and water as a heat transfer fluid. This fluid is circulated by a magnetically coupled centrifugal pump through the refrigeration and heating system and the fluid shell surrounding the test chamber.

⚠ Warning: Using unapproved chamber fluid can cause fluid circulation issues which can result in inaccurate humidity output. Contact Thunder Scientific for more information.

2.12.3.1 Chamber Fluid Filling Procedure

1. Ensure main power switch is OFF.
2. Remove top console panel.
3. Remove insulation and locate the "Fluid Fill Port".
4. Remove "Red" cap and insert funnel into fluid fill port.
5. Add 2 gallons of 70% propylene glycol. Fill the remainder with water (approximately 1 to 1.5 gallons) until level is approximately 2" (50.8 mm) below the top of the fill port. Total capacity is around 3 to 3.5 gallons.
6. Remove funnel and replace red fluid fill port cap and insulation.
7. Operate generator for 10 minutes, recheck fluid level and top off if low.
8. Replace top console panel.

Refer to drawings: [18D29901-1](#), [18D29901-4](#), [18D29909-1](#)

2.12.3.2 Chamber Fluid Draining Procedure

1. Ensure main power switch is OFF.
2. Remove rear console panel.
3. Locate drain hose in the lower left rear corner of the generator (when looking at the back of the generator). It is the black hose with the yellow tip and brass cap.



4. Extend the hose and elevate it, then remove drain hose cap and empty the chamber fluid into a clean container with a minimum size of 4 gallons. Save the chamber fluid for refilling.

5. To restore hose: grasp hose and rotate counterclockwise ½ turn while pushing hose into left side storage cavity.
6. Replace rear console panel.

Refer to drawings: [18D29901-1](#), [18D29901-3](#), [18D29909-2](#)

2.12.4 Reservoir Initial Filling Procedure

The reservoir requires an initial filling prior to first use, then periodic filling thereafter.

Refer to section [5.1 Water Reservoir Level](#) for detailed instruction on how to fill the reservoir.

2.12.5 Setting Supply Pressure Regulator

The supply pressure must be regulated to assure proper control and operation. The goal of the regulation is to remove the spikes that occur during air supply generation.

Note – *It is always recommended to double regulate the air supply; once at the supply and again at the 2900.*

Adjust the 2900's internal pressure regulator (REG) to 10 psiG below the supply pressure, but never above 150 psiG. For example, if the supply pressure indicates 165 psiG then adjust the internal pressure regulator to 150 psiG. If the supply pressure indicates 155 psiG then adjust the internal pressure regulator to 145 psiG (10 psiG below). For the best results operate the generator in run mode at the default flow rate to assure the regulator adjustment corrects for any pressure drop caused by the flow rate.

1. Open the Supply Pressure Dialog by selecting "Supply Pressure" from the Utilities Menu Tab
2. Using a #6 or #8 straight blade screwdriver, rotate stem clockwise to increase pressure and counterclockwise to decrease pressure while monitoring the supply pressure dialog window.

Refer to drawings: [18D29901-1](#), [18D29901-3](#), [18D29901-8](#)

2.13 QUICK START

This section will provide the user a quick start on operating the generator. For detailed information on operating the generator please refer to section [4 ControLog Interface](#).

CAUTION!

DO NOT OPERATE THE GENERATOR WITHOUT CHAMBER FLUID.

2.13.1 Power-Up

To Power-Up the generator perform the following steps:

- Verify that the air supply connection has been made.
 - If using the Series ACS2520 Air Compressor System (ACS)⁸ verify the following:
 - The On/Off valve is open (handle inline).
 - The AC power cable is connected to the ACS box.
 - The remote air compressor control cable is connected from ACS box to generator.
 - The Remote/Manual switch on the left side of the ACS box is in the Remote position.
 - Toggle the power switch located on the left side of the ACS box to ON.

Note – *When the Remote/Manual switch is in the Remote position the ACS compressor will not run when first switched to ON. The compressor is remotely controlled by the 2900 and will not start until the user requests an operation that requires supply pressure.*

- If using another air source, verify the following:
 - Supply is on and properly regulated.
- Verify that AC power cable is connected to the generator.
- Toggle the power switch located at the lower right rear of generator to ON. The generator will begin to boot up.

⁸ Refer to Thunder Scientific's website www.thunderscientific.com for the ACS2520 manual and more information on the ACS2520.

2.13.2 Loading Screen

After the system boots the generator will show a loading screen which will indicate the status of the loading process and will also show the software version of the generator.



2.13.3 ControLog Screen

Upon completion of the loading process the generator will show the main ControLog page and a dialog showing the status of establishing communication with the generator.

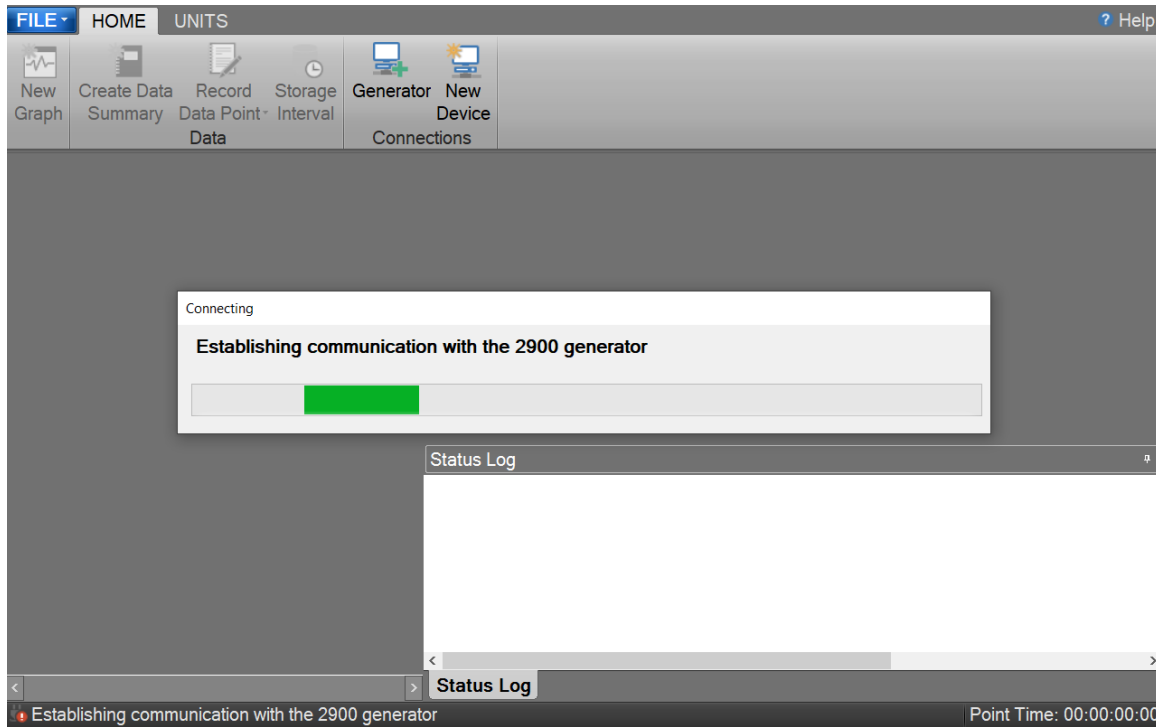

Once communication with the generator is established the generator's parameter and data tabs will be displayed.

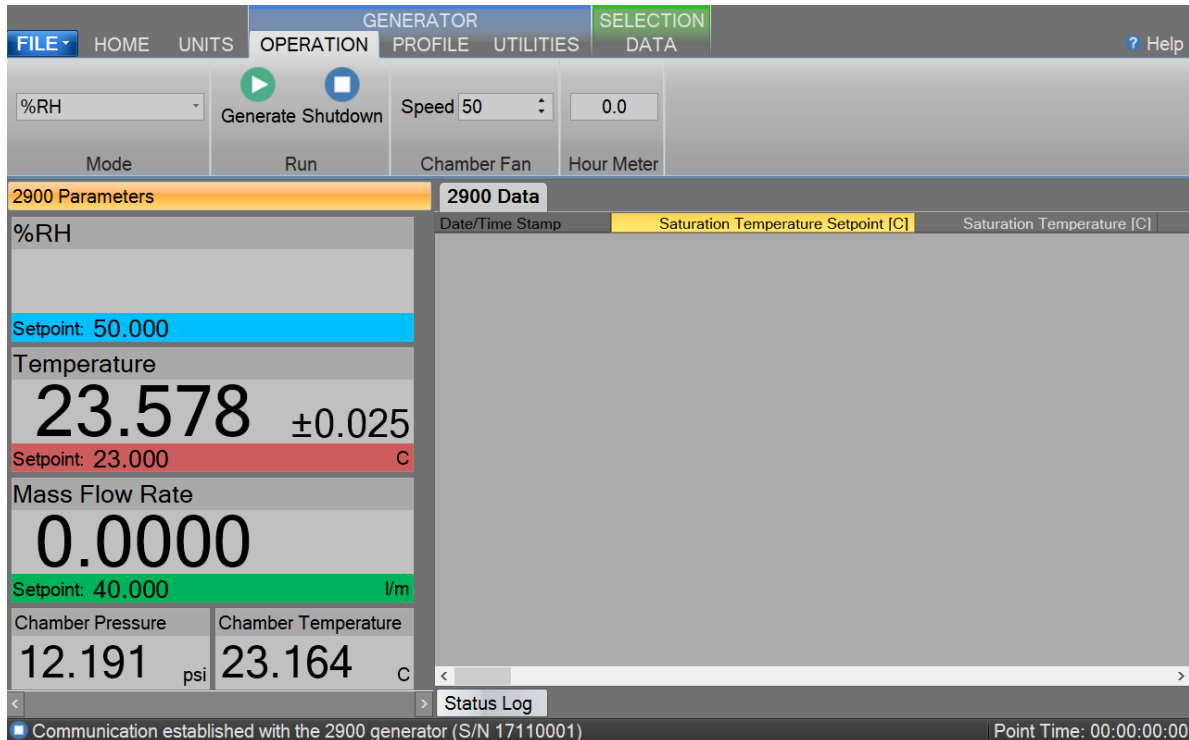

2.13.4 Control Parameters

The Parameter Tab Group is located on the left side of the application and contains a parameter tab for each connected device. The 2900 Parameters contain all the control and measurement parameters critical to the operation of the humidity generator.

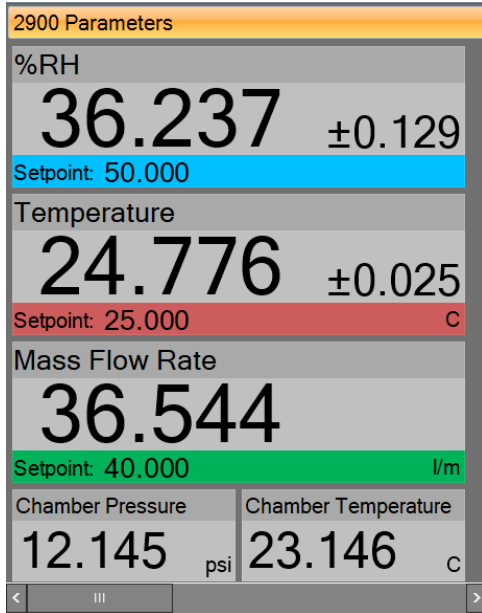

Scrolling the Parameters

Each Parameter Tab can be scrolled up and down to show additional parameters.

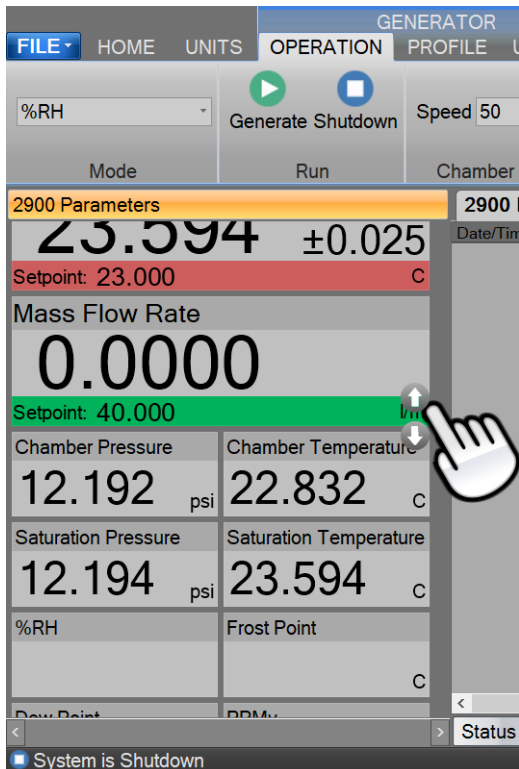

2.13.4.1 Setpoint Tile

The Setpoint Tiles allow the user to control the operation of the humidity generator by changing the desired setpoint that the generator will control to. The Tiles contain 5 key parts; a header with the Parameter Name, the Actual Value, the real-time Uncertainty Value, the Setpoint Value and the Unit the values are displayed in. Each setpoint tile has a colored bar to allow quick indication of the what the tile is displaying and in turn what the system is controlling. Blue is for the humidity that is being generated, red is for the temperature that the system is controlling to and green is for the flow rate the system is generating at.

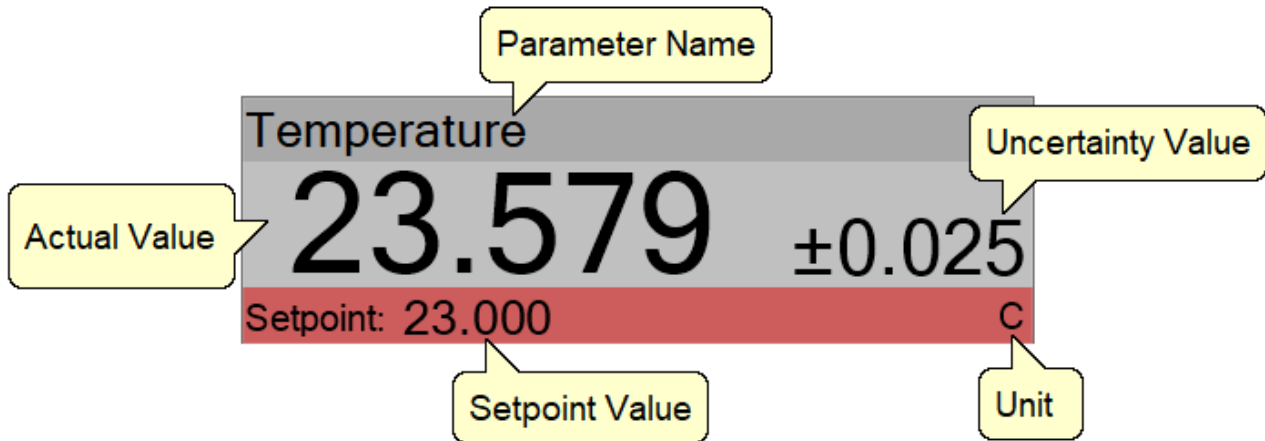

2.13.4.1.1 Changing Setpoints

To change a setpoint, click on the setpoint tile that you would like to change. A setpoint entry box will appear. For example, to change the Percent Relative Humidity setpoint click on the %RH setpoint tile.

The screenshot shows a dialog box titled 'Enter Setpoint Value'. Inside the dialog, there is a prompt: 'Enter the %RH you would like to generate.' Below the prompt is a text input field with a dropdown arrow on the right side. At the bottom right of the dialog are two buttons: 'Ok' and 'Cancel'.

Enter the new value into the Setpoint Entry box and select Ok. Notice that the Percent Relative Humidity setpoint value updates to the new value and the actual values begin moving toward the new setpoint.

2.13.4.2 Value Tile

The Value Tiles display an actual value of a given parameter to the user. The Tiles contain 3 key parts; a header with the Parameter Name, the Actual Value and the Unit the value is displayed in.

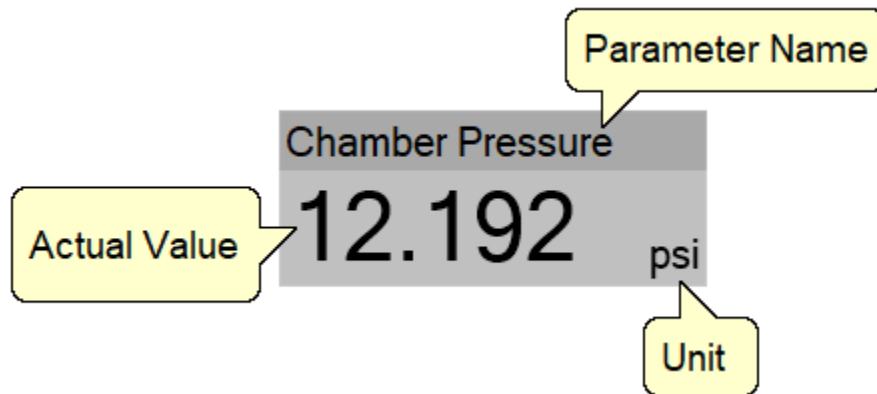

2.13.5 Control Modes

The user can change the operating mode of the 2900 by selecting from the drop-down menu within the Mode group on the Generator's Operation menu tab.

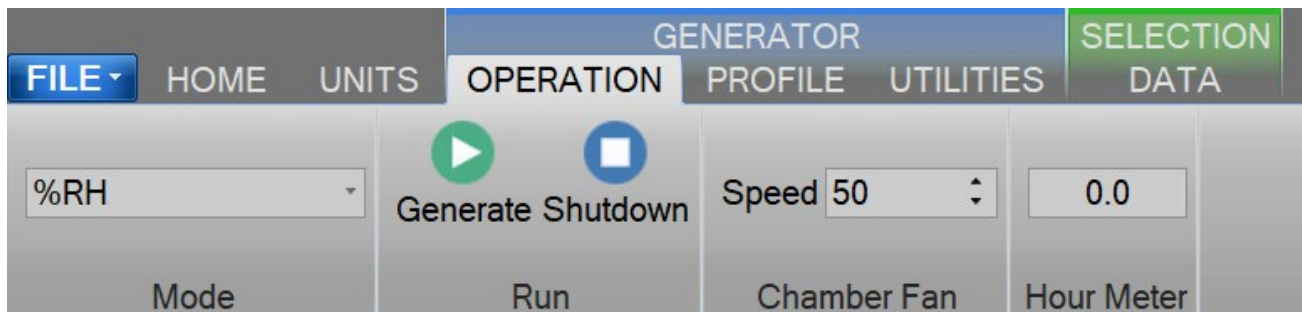

The drop-down allows the user to select between %RH, Frost Point, Dew Point, PPMv, PPMw, and Saturation Pressure.

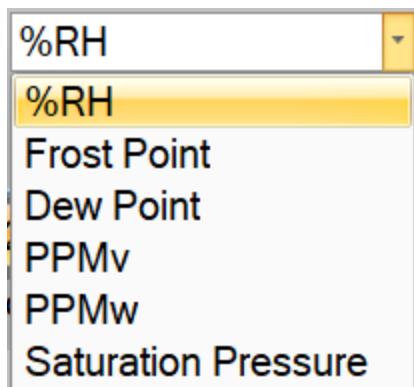

2.13.6 Generating and Shutting down

The Run Menu allows the user to run the 2900 manually.

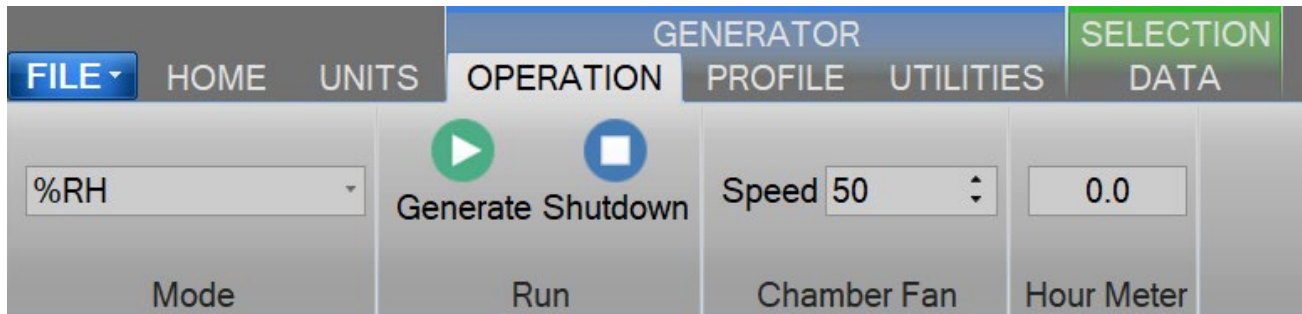

The user can select to Generate or Shutdown.

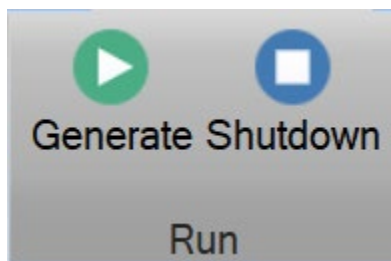

2.13.6.1 Generate Mode

Selecting Generate from the run menu commands the 2900 into generate mode. When in the Generate mode of operation, the system will control at the currently entered setpoints. Anytime a setpoint is changed, the system immediately begins adjusting to that new value, and will control at the new point. The Generate mode also allows you to change the humidity control mode at any time. For instance, the system may be controlling %RH, then you may immediately switch to Dew Point control mode.

2.13.6.2 Shutdown

Selecting Shutdown from the run menu commands the 2900 to shutdown. The 2900 may be shutdown whenever it is generating. When stopped, all system functions shutdown, pressure is vented, and the idle Control/Display screen is shown. During this idle time, when the 2900 is stopped, gas is not flowing through the generator.

2.13.7 Power-Off

To turn the system off select the “Turn Off” command.

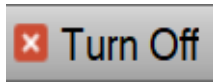

The “Turn Off” command is located under the “File” menu.

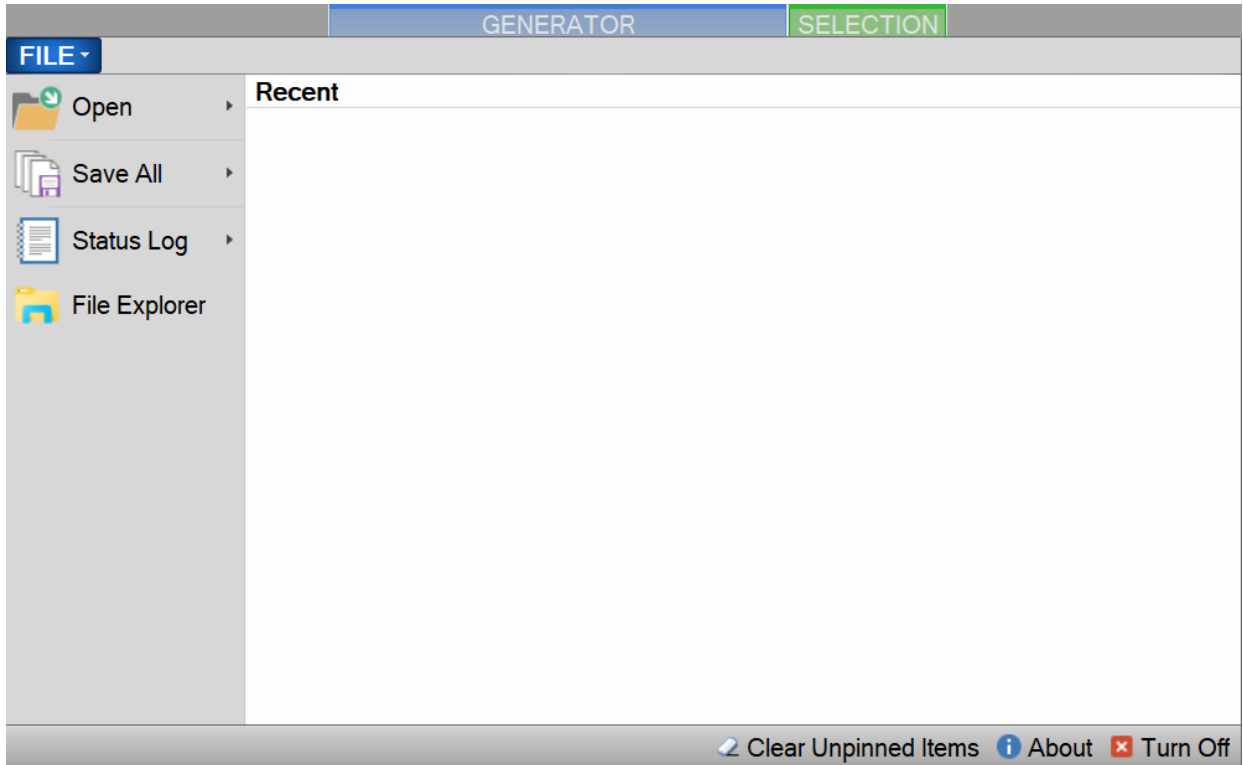

The Turn Off command will properly exit the software and shutdown the computers so that the main power switch can be switched off.

Note – Always perform a [Shutdown](#) from the Operation Menu Tab before turning off the System.

If there is current data that has yet to be saved the user will be asked to save the data before the system shuts down. Selecting this command when the generator is generating will result in the automatic shutdown of the generator.

The user is safe to switch the power switch to OFF once the PC has shut down completely (display goes blank).

CAUTION!

TURNING OFF POWER WITHOUT SHUTTING DOWN THE SYSTEM FIRST CAN CORRUPT THE EMBEDDED WINDOW SYSTEM DRIVE.

2.13.8 Set Date and Time

The user can change the current system date and time through the status bar context menu.

Note – *To avoid time stamp confusion only change the system date and time when the generator is shutdown and not recording data.*

Start by long pressing or right clicking anywhere within the status bar. A long press is when you touch and hold the screen.



Long enough for a square selection box to appear.



Releasing will open the status bar context menu.

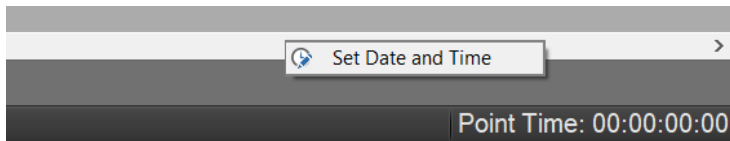

Select “Set Date and Time” from the context menu to open the system Date and Time dialog.

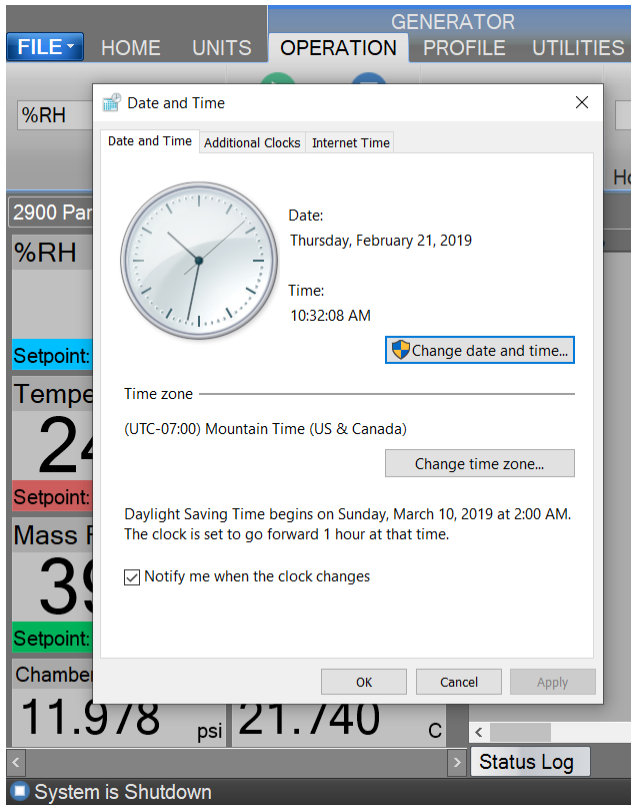

2.13.9 Help

The Help Menu located on the upper right side of the screen, allows the user to open the 2900 System Manual.

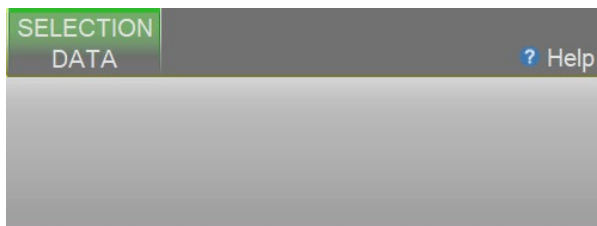

Note – Refer to the Thunder Scientific website (www.thunderscientific.com) for the latest manual edition and other information on your Model 2900 Humidity System.

REVISIONS				
DWN	REV.	DESCRIPTION	DATE	APP. BY
DWF	A	TRANSDUCERS UPDATED - TIMER ADDED IN ELEC. BOX	06/23/2020	BB
BRH	B	SOLID STATE RELAYS UPDATED & REFRIGERATION RECEIVER ADDED	09/08/2022	BB
BRH	C	ADD CALLOUT FOR HLS3,H4,H5	05/08/2024	BB

ITEM NO.	FIND #	TSC STOCKCODE	DESCRIPTION	QTY.
59	V3	PR4-EPRT	1/4" PLUG VALVE	1
58	V2	D16A29022	EXPANSION VALVE ASSEMBLY	1
57	V1	D16A29021	FLOW VALVE ASSEMBLY	1
56	TR5	D20A29043	2900 TIMER RELAY ASSEMBLY	1
55	T6	P528-500	0 - 500 PSI PRESSURE SENSOR	1
54	T5	P528-100	0 - 100 PSI PRESSURE SENSOR	1
53	T4	EFM5700-50L	MASS FLOW TRANSDUCER	1
52	T3	CPT6020-17	8 - 17 PSIA PRECISION TRANSDUCER	1
51	T2	CPT6020-160	0 - 160 PSIA PRECISION TRANSDUCER	1
50	T1	D19A29072	SUPPLY TRANSDUCER ASSEMBLY	2
49	SSRB1,2	G4PB4	4 CHANNEL MOUNTING RACK	2
48	SSR-DC6	G4DC5	G4ODC5 OPTO 22 SSR (60 VDC / 3 A)	1
47	SSR-DC0-5,7	G4DC5A	G4ODC5A OPTO 22 SSR (200 VDC / 1 A)	7
46	SSR-AC2,3	EL240A10-05	5 AMP SS RELAY	2
45	SSR-AC0,1	UPD2415DF	15 AMP SS RELAY	2
44	SOL4	A2037	PRE SAT FILL SOLENOID VALVE	1
43	SOL3	A2231	PRESSURE VENT SOLENOID VALVE	1
42	SOL2	K2X2833	COOL SOLENOID VALVE	1
41	SOL1	A2033	AIR SUPPLY SOLENOID VALVE	1
40	RV1	S4C-150	1/4" MALE NPT ADJUSTABLE RELIEF VALVE	1
39	RTD5	S17624	CABINET TEMPERATURE PROBE	1
38	RTD4	5606-50-B	CHAMBER TEMPERATURE PROBE (2")	1
37	RTD3	5606-50-B	EXPANSION VALVE TEMPERATURE PROBE (2")	1
36	RTD2	5606-50-B	PRE SAT TEMPERATURE PROBE (2")	1
35	RTD1	AM1612-3	SATURATION TEMPERATURE PROBE (3")	1
34	RESERVOIR	D16A29015	RESERVOIR ASSEMBLY	1
33	REG	F10001062T	PRESSURE REGULATOR	1
32	PEM	EF-12	POWER ENTRY MODULE	1
31	NI9403	N779787	TTL DIGITAL I/O MODULE (32 CH)	1

ITEM NO.	FIND #	TSC STOCKCODE	DESCRIPTION	QTY.
30	NI9401	N779351	TTL DIGITAL I/O MODULE (8 CH)	1
29	NI9216	N783664-01	24-BIT 100 Ω RTD ANALOG INPUT MODULE	1
28	NI9209	N783729	±10V, 24-BIT ANALOG INPUT MODULE	1
27	NI9136	N784238	CDAQ-9136 4 SLOT CONTROLLER	1
26	MOXA	UPORT1650-8	USB - SERIAL HUB	1
25	MEM	SD1001	2GB FLASH MEMORY CARD	1
24	LR	BT-RECR	REFRIGERATION RECEIVER	1
23	LL2P	D18A29063	PRESAT LIQUID LEVEL PROBE	1
22	LL2	D92A00043	LIQUID LEVEL ALARM PROBE BOARD ASSY	1
21	LL1P	D94A25049	RESERVOIR LIQUID LEVEL PROBE ASSY	1
20	LL1	D94A25051	LIQUID LEVEL, RES PROBE ASSY	1
19	HMI	UTC-510GP	UTC-510 10.1" TOUCH COMPUTER	1
18	HLS3	THRMS110	110° C THERMOSTAT SWITCH	1
17	HLS2	HLSW2-EPOXY	190 °F THERMOSTAT - EPOXY COATED	1
16	HLS1	HLSW1	212° THERMOSTAT SWITCH	1
15	H4,5	HK5161	22.0 OHM FOIL HEATER	2
14	H2,3	L3A94	400 WATT CARTRIDGE HEATER	2
13	H1	N8A21	1KW CARTRIDGE HEATER	1
12	G1	G6X114	200 PSIG PRESSURE GAUGE	1
11	FS1	D18A29060	PRESSURE SWITCH ASSEMBLY	1
10	FP1	D17A29059	FLUID PUMP ASSEMBLY	1
9	FD	C-032-S	REFRIGERATION FILTER / DRYER	1
8	FAN2	D17A29065	CHAMBER FAN ASSEMBLY	1
7	FAN1	FAN-6-24VDC	Ø 6.0" 24 VDC AXIAL FAN	6
6	EX1	D16A29045	EVAPORATOR WELD ASSEMBLY	1
5	DC3	SD-15A-05	5VDC POWER SUPPLY	1
4	DC2	VE-LU3-EU	24V 200W POWER SUPPLY	1
3	DC1	VE-LU1-EW	12V 100W POWER SUPPLY	1
2	CON	BT-COND	CONDENSER ASSEMBLY	1
1	C1	COMPR-220V	220V REFRIGERATION COMPRESSOR	1

DO NOT SCALE FROM DRAWING	
NEXT ASSY	USED ON
APPLICATION	

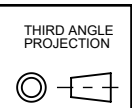

TOLERANCES
 .XXX ±.010
 .XX ±.015
 < ±.50°
 UNLESS NOTED OTHERWISE

PROPRIETARY NOTICE
 THIS DRAWING AND INFORMATION CONTAINED WITHIN IS PROPRIETARY TO THUNDER SCIENTIFIC AND CANNOT BE COPIED OR REPRODUCED WITHOUT SPECIFIC WRITTEN PERMISSION

DRAWN	FURRY	08/05/2018
APPROVED	BB	08/21/2018
ISSUED	DWF	08/21/2018

Thunder Scientific Corporation
 623 Wyoming S.E. Albuquerque, NM 87123

2900 Components

SIZE	DWG. NO.	REV
A	18D29901	C
WT. 298.59		SHEET 1 OF 11

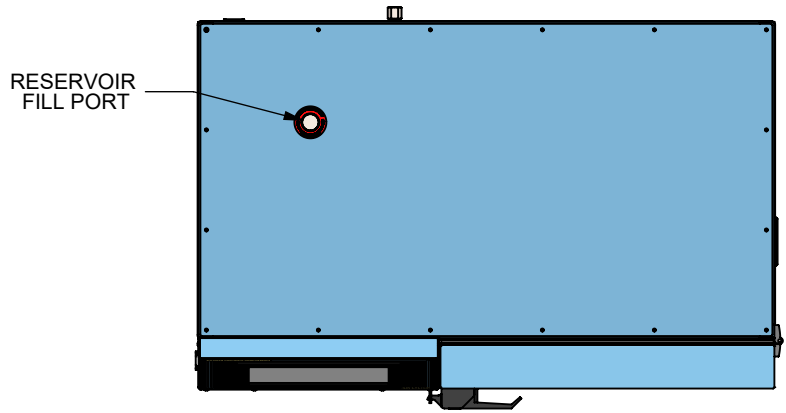

TOP VIEW

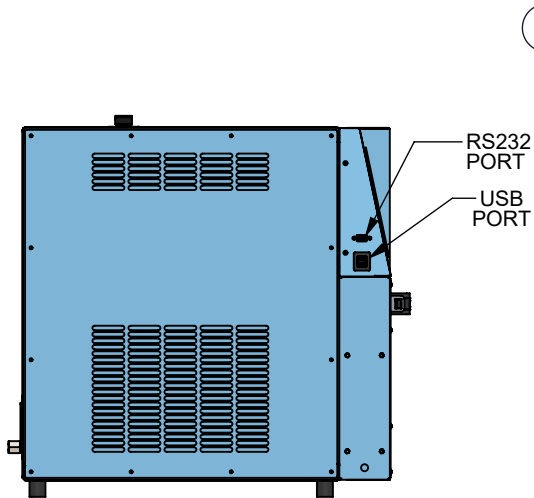

LEFT SIDE

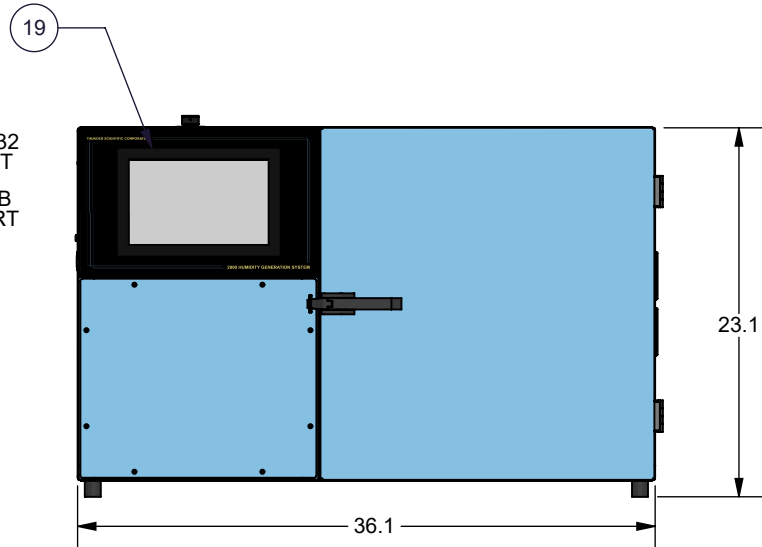

FRONT

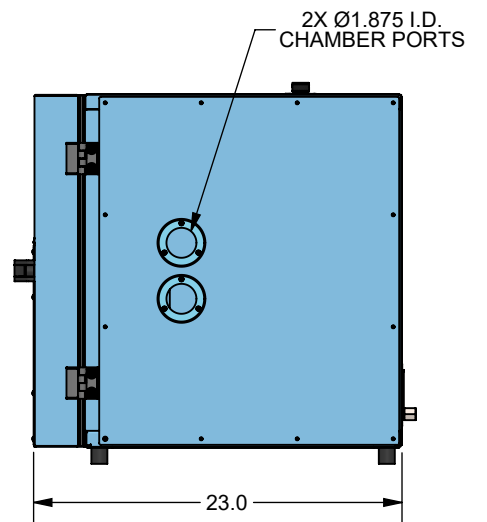

RIGHT SIDE

DO NOT SCALE FROM DRAWING		THIRD ANGLE PROJECTION	PROPRIETARY NOTICE THIS DRAWING AND INFORMATION CONTAINED WITHIN IS PROPRIETARY TO THUNDER SCIENTIFIC AND CANNOT BE COPIED OR REPRODUCED WITHOUT SPECIFIC WRITTEN PERMISSION			Thunder Scientific Corporation 623 Wyoming S.E. Albuquerque, NM 87123			
						2900 Components			
			TOLERANCES .XXX ±.010 .XX ±.015 ∠ ±.50° UNLESS NOTED OTHERWISE			DRAWN FURRY APPROVED BB ISSUED DWF	08/05/2018 08/21/2018 08/21/2018	SIZE A DWG. NO. 18D29901 WT. 298.59	REV C SHEET 2 OF 11
NEXT ASSY	USED ON								
APPLICATION									

CHAMBER FAN COMPONENTS
SEE 18D29908

8

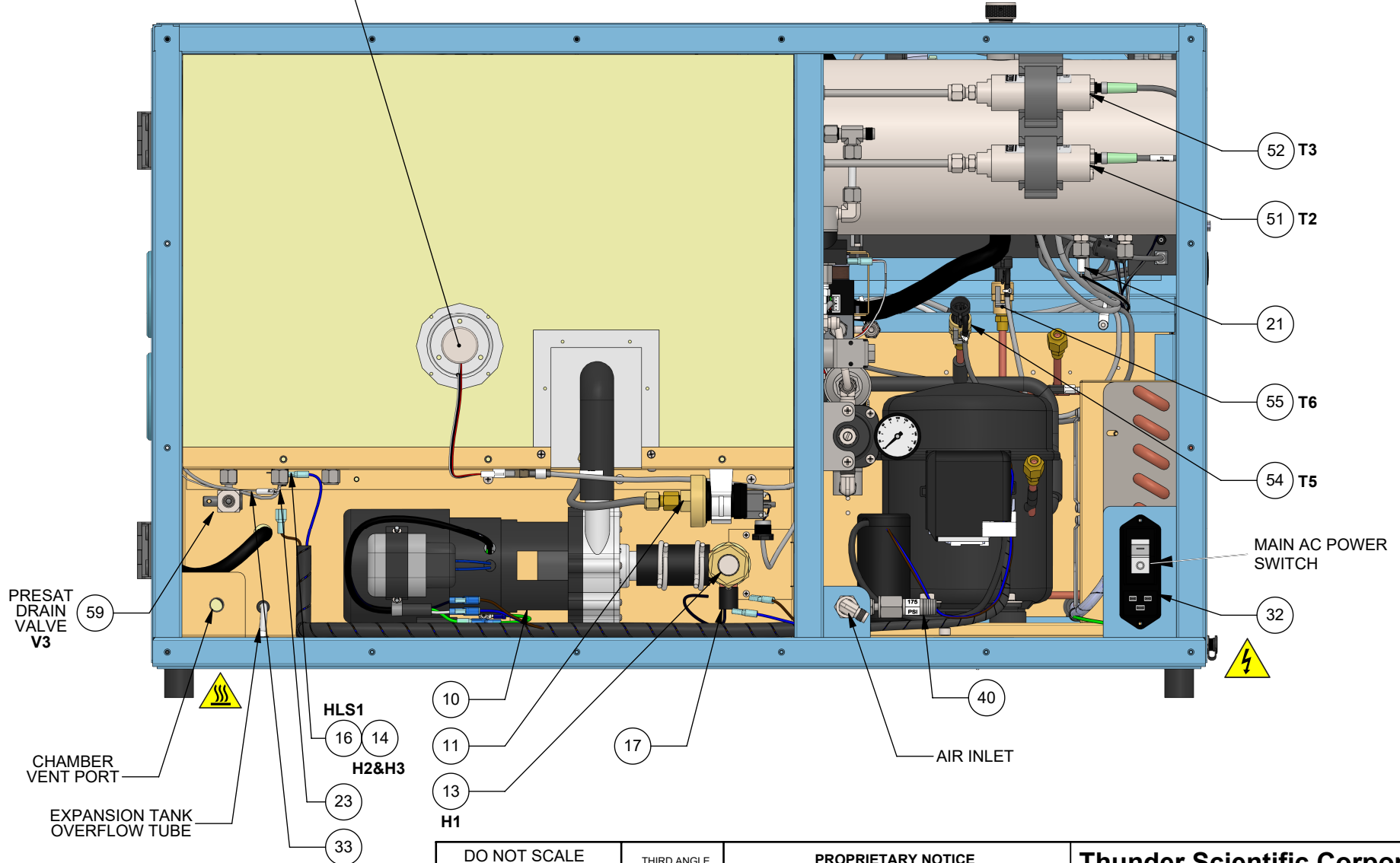

PRESAT DRAIN VALVE V3

59

CHAMBER VENT PORT

EXPANSION TANK OVERFLOW TUBE

HLS1

16

14

H2&H3

23

33

10

11

13

H1

17

40

AIR INLET

52

T3

51

T2

21

55

T6

54

T5

MAIN AC POWER SWITCH

32



DO NOT SCALE FROM DRAWING		THIRD ANGLE PROJECTION	PROPRIETARY NOTICE THIS DRAWING AND INFORMATION CONTAINED WITHIN IS PROPRIETARY TO THUNDER SCIENTIFIC AND CANNOT BE COPIED OR REPRODUCED WITHOUT SPECIFIC WRITTEN PERMISSION			Thunder Scientific Corporation 623 Wyoming S.E. Albuquerque, NM 87123		
			TOLERANCES .XXX ±.010 .XX ±.015 ∠ ±.50° UNLESS NOTED OTHERWISE			2900 Components		
NEXT ASSY	USED ON		DRAWN	FURRY	08/05/2018	SIZE A	DWG. NO.	REV
APPLICATION			APPROVED	BB	08/21/2018		18D29901	C
			ISSUED	DWF	08/21/2018	WT. 298.59		SHEET 3 OF 11

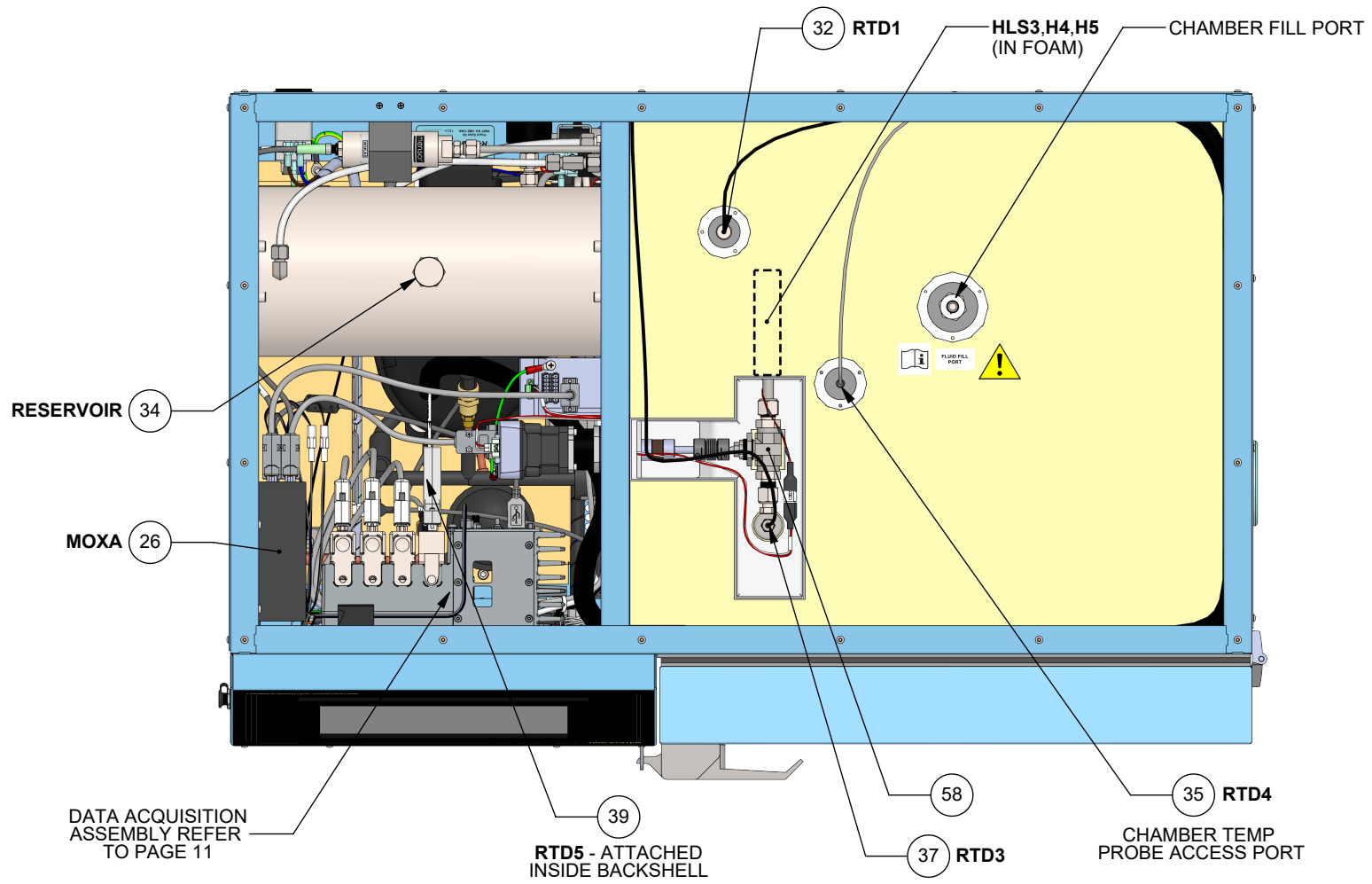

DO NOT SCALE FROM DRAWING		THIRD ANGLE PROJECTION	PROPRIETARY NOTICE THIS DRAWING AND INFORMATION CONTAINED WITHIN IS PROPRIETARY TO THUNDER SCIENTIFIC AND CANNOT BE COPIED OR REPRODUCED WITHOUT SPECIFIC WRITTEN PERMISSION			Thunder Scientific Corporation 623 Wyoming S.E. Albuquerque, NM 87123		
			TOLERANCES .XXX ±.010 .XX ±.015 ∠ ±.50° UNLESS NOTED OTHERWISE			DRAWN FURRY APPROVED BB ISSUED DWF	08/05/2018 08/21/2018 08/21/2018	2900 Components
NEXT ASSY	USED ON		SIZE A	DWG. NO. 18D29901	REV C	WT. 298.59		SHEET 4 OF 11
APPLICATION								

REVISIONS				
DWN	REV.	DESCRIPTION	DATE	APP. BY
BRH	A	CLARIFY FILL INSTRUCTIONS ; ADD DETAIL "A"	06/05/2025	BB

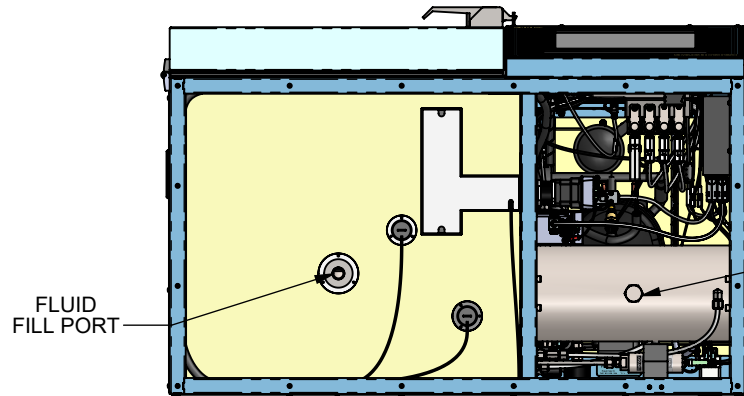

DISTILLED WATER ONLY

CHAMBER FLUID FILLING REQUIRES:

- T10 TORX DRIVER
- FUNNEL ASSEMBLY
- 2 U.S. GAL. PROPYLENE GLYCOL
- 1 TO 1.5 U.S. GAL. WATER

CHAMBER FLUID FILLING INSTRUCTIONS

1. REMOVE TOP CONSOLE PANEL AND INSULATION INSERT.
2. LOCATE FILL PORT.
3. REMOVE RED CAP AND INSERT FUNNEL INTO FILL PORT.
4. ADD 2 U.S. GALLONS OF PROPYLENE GLYCOL THEN FILL REMAINDER WITH WATER (APPROX. 1 TO 1.5 GALLONS) UNTIL LEVEL IS 2" (~50.8 mm) BELOW THE TOP OF THE FILL PORT STUB. TOTAL CAPACITY IS 3 TO 3.5 GALLONS.
5. REMOVE FUNNEL AND REPLACE RED CAP.
6. OPERATE GENERATOR FOR 10 MINUTES. RECHECK FLUID LEVEL AND TOP OFF IF LOW.
7. REPLACE INSULATION INSERT AND TOP CONSOLE PANEL.

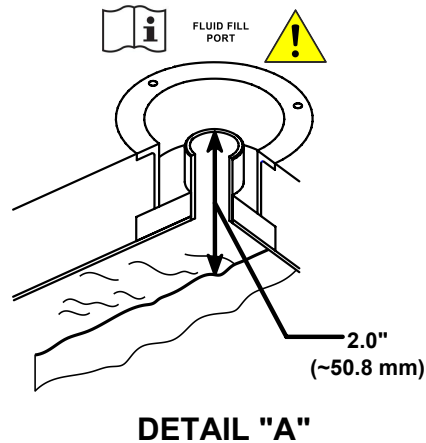
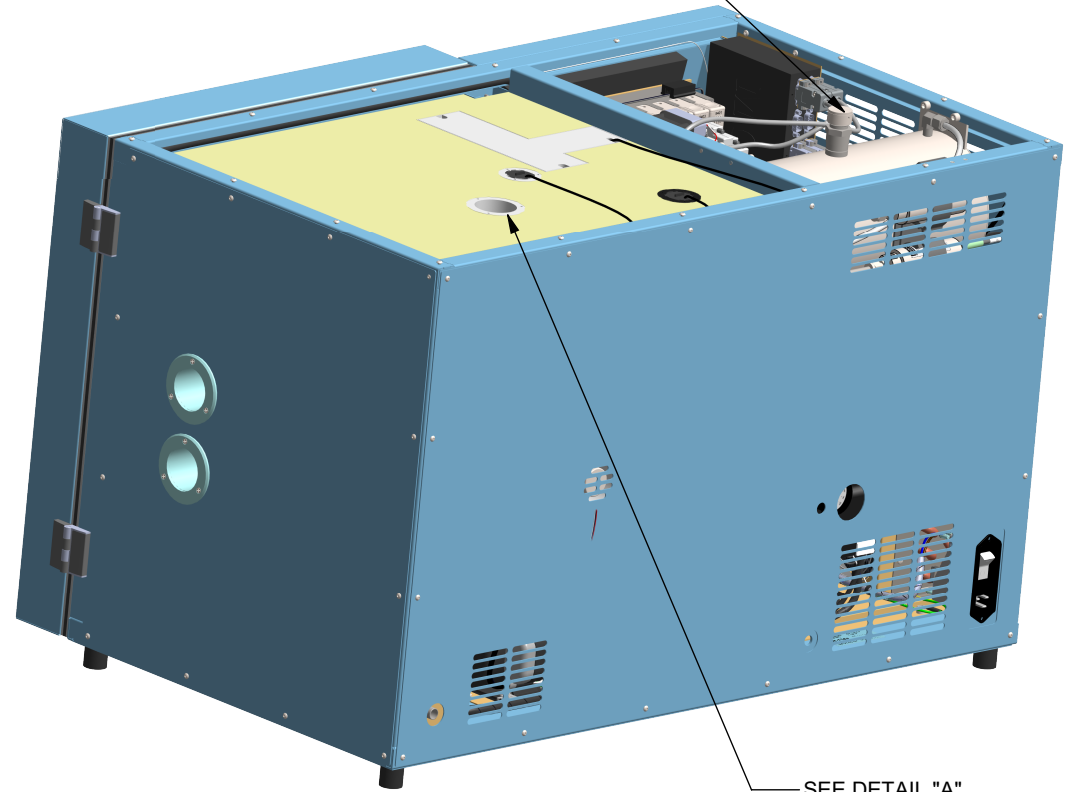

DO NOT SCALE FROM DRAWING		THIRD ANGLE PROJECTION	PROPRIETARY NOTICE THIS DRAWING AND INFORMATION CONTAINED WITHIN IS PROPRIETARY TO THUNDER SCIENTIFIC AND CANNOT BE COPIED OR REPRODUCED WITHOUT SPECIFIC WRITTEN PERMISSION		Thunder Scientific Corporation 623 Wyoming S.E. Albuquerque, NM 87123	
NEXT ASSY		TOLERANCES .XXX ±.010 .XX ±.015 ∠ ±.50° UNLESS NOTED OTHERWISE		DRAWN FURRY 07/26/2018	Fluid Fill / Drain Instructions	
USED ON		APPROVED BB 07/26/2018		ISSUED DWF 07/26/2018	SIZE A	DWG. NO. 18D29909
APPLICATION		UNLESS NOTED OTHERWISE		ISSUED DWF 07/26/2018	WT. 285.44	REV A
						SHEET 1 OF 2

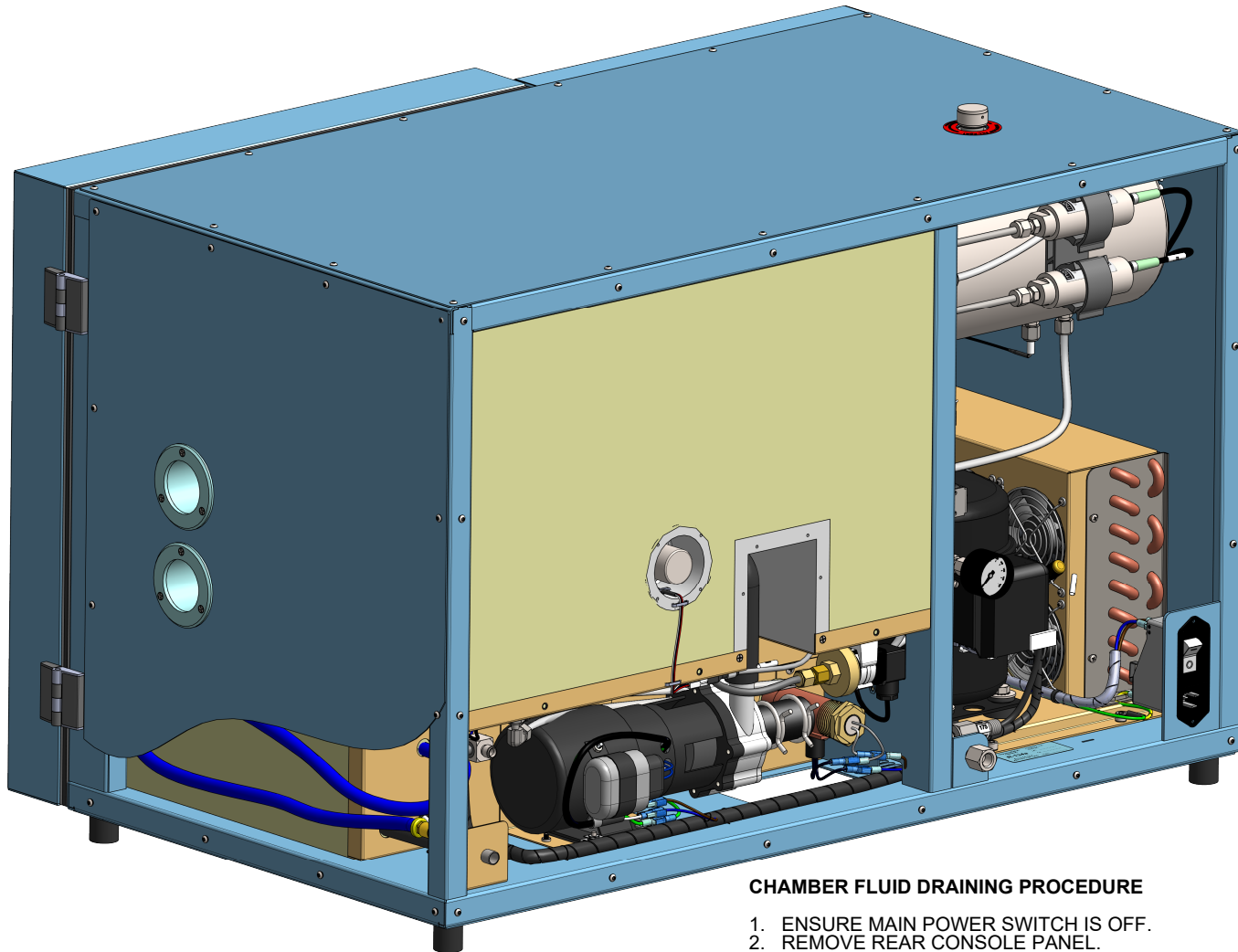

CHAMBER FLUID DRAINING PROCEDURE

1. ENSURE MAIN POWER SWITCH IS OFF.
2. REMOVE REAR CONSOLE PANEL.
3. LOCATE DRAIN HOSE IN THE LOWER LEFT REAR CORNER OF THE GENERATOR (WHEN LOOKING AT THE BACK OF THE GENERATOR).
4. EXTEND AND ELEVATE HOSE, REMOVE DRAIN HOSE CAP AND EMPTY THE CHAMBER FLUID INTO A CLEAN CONTAINER WITH A MINIMUM SIZE OF 4 GALLONS. SAVE THE CHAMBER FLUID FOR REFILLING.
5. TO RESTORE HOSE: GRASP HOSE AND ROTATE COUNTER CLOCKWISE 1/2 TURN WHILE PUSHING HOSE INTO LEFT SIDE STORAGE CAVITY. REPLACE REAR CONSOLE PANEL.

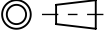
DO NOT SCALE FROM DRAWING		THIRD ANGLE PROJECTION 	PROPRIETARY NOTICE THIS DRAWING AND INFORMATION CONTAINED WITHIN IS PROPRIETARY TO THUNDER SCIENTIFIC AND CANNOT BE COPIED OR REPRODUCED WITHOUT SPECIFIC WRITTEN PERMISSION			Thunder Scientific Corporation 623 Wyoming S.E. Albuquerque, NM 87123		
			TOLERANCES .XXX ±.010 .XX ±.015 ∠ ±.50° UNLESS NOTED OTHERWISE			Fluid Fill / Drain Instructions		
NEXT ASSY	USED ON		DRAWN	FURRY	07/26/2018	SIZE	DWG. NO.	REV
			APPROVED	BB	07/26/2018	A	18D29909	A
APPLICATION			ISSUED	DWF	07/26/2018		WT. 285.44	SHEET 2 OF 2