

Operation and Maintenance Manual
for the
ACS3920
CO2 Free / Dry Air Compressor System



Thunder Scientific[®] Corporation

623 Wyoming Blvd. SE ✎ Albuquerque, New Mexico 87123-3198
Ordering: (800) 872.7728 ✎ Tel: (505) 265.8701 ✎ FAX: (505) 266.6203

www.thunderscientific.com

Copyright © 2026 by Thunder Scientific Corporation, All Rights Reserved

ACS3920 Operation and Maintenance Manual
Document Edition – 005

April 2026

THUNDER SCIENTIFIC® is the registered trademark of Thunder Scientific Corporation.
All the information provided in this document is correct and true at the time of publication.

TABLE OF CONTENTS

1	INTRODUCTION	4
2	SPECIFICATIONS and ENVIRONMENTAL CONDITIONS.....	4
	2.1 Specifications	4
	2.2 Environmental Conditions	4
	2.3 Warranty	4
3	SAFETY GUIDELINES	5
4	INSTALLATION	5
	4.1 Unpacking	5
	4.2 Location	5
	4.3 Air Supply Tubing	6
	4.4 Power	6
	4.5 Remote-Control ACS Cable.....	6
5	COMPONENTS and CONTROLS.....	6
	5.1 Power Switch	6
	5.2 Remote/Manual Operation Switch	6
	5.3 Hour Meter	6
	5.4 Air Compressor	6
	5.5 Compressed Air Membrane Dryer	7
	5.6 Input Pressure Regulator	7
	5.7 CO2 Adsorber/Dryer Inlet Pressure Regulator	7
	5.8 Outlet Pressure Regulator	7
	5.9 Dimensional Drawing	8
	5.10 Component Locations	9 & 10
6	GENERAL OPERATION	11
	6.1 Start-up	11
	6.2 Input Pressure Adjustment	11
	6.3 Shutdown	11
7	INSPECTION and MAINTENANCE	11
	7.1 Recommended Maintenance Schedule.....	11
	7.2 Filter Inspection and Replacement	12
	7.3 Storage Procedures.....	13
	7.4 Service Kit.....	13
	7.5 Heat Limit Switch	13
8	SCHEMATICS	14
	8.1 Pneumatic Schematic	14
	8.2 Electrical Schematic 110 VAC	15
	8.3 Electrical Schematic 220 VAC	16
9	TROUBLESHOOTING GUIDE	17
10	PARTS LIST	17

1 INTRODUCTION

The ACS3920 Air Compressor System with integral CO2 Adsorber/Dryer is designed to be used as the gas supply for the Thunder Scientific 3920 Low Humidity Generator. The ACS3920 Air Compressor System consists of a vibration isolated oil-less compressor, membrane style air dryer, CO2 Adsorber/Dryer, and adjustment regulators, all incorporated into a sound muffling cabinet. The ACS3920 is ideal for laboratory use because of its 100 psiG pressure output at 15 L/min capability, 100% duty cycle, low sound level of less than 70 db(A), and long service life.

2 SPECIFICATIONS and ENVIRONMENTAL CONDITIONS

2.1 Specifications

Voltage/Frequency: 110-120/115-120VAC 50/60Hz, 7A
Voltage/Frequency (Optional): 220-240/230-240VAC 50/60Hz, 3.5A
Pressure Output (maximum): 100 psiG
Pressure Frost Point (minimum): -70 °C
Flow Rate (maximum): 10 L/min
Sound Level: <70 db(A)
Duty Cycle: 100%
Physical Dimensions: 28.9 w" x 18.1 d" x 14.2 h" (73.4 cm x 46 cm x 36 cm)
Dry Weight: 75 lbs.

2.2 Environmental Conditions

Operating Temperature: 15 to 30 °C
Storage Temperature: > 0 to 50 °C
Humidity: 5 to 90% non-condensing

2.3 Warranty

Thunder Scientific Corporation (TSC) warrants this product to be free of defects in material and workmanship under normal use and service when operated within the specified design limitations for a period of 90 days from date of shipment or 2000 operating hours, whichever comes first. TSC's obligation under this warranty shall be limited to the following: Product is returned to TSC with transportation charges prepaid and that TSC's examination reveals the Product to be defective, TSC, at its option, shall repair or replace at TSC's plant, any part or parts of the Product which is or are defective. This warranty shall not apply to any Product that has become damaged or inoperative because of ordinary wear, misuse, cold, heat, rain, excessive humidity, freeze damage, use of improper chemicals, negligence, accident, failure to operate the product in accordance with the instructions provided in the Owners Manual(s) supplied with the product, improper maintenance, the use of accessories or attachments not recommended by TSC or unauthorized repair or alterations.

THIS WARRANTY IS EXCLUSIVE AND IN LIEU OF ANY WARRANTY OF MERCHANTABILITY, FITNESS FOR A PARTICULAR PURPOSE OR ANY OTHER WARRANTY, WHETHER EXPRESS OR IMPLIED, AND ALL OTHER LIABILITIES AND OBLIGATIONS ON THE PART OF TSC; TSC SHALL NOT BE LIABLE FOR ANY INCIDENTAL, INDIRECT OR CONSEQUENTIAL LOSS, DAMAGE, OR EXPENSE THAT MAY RESULT FROM ANY DEFECT, FAILURE OR MALFUNCTION OF THE PRODUCT.

All warranties: express or implied, with respect to any device or component not manufactured by TSC but incorporated into its Product are the responsibility of the original manufacturer and shall not affect or apply to TSC.

3 SAFETY GUIDELINES

All compressed gases, including air, can be dangerous. Know and follow all safety rules when using compressed air and especially when disconnecting and venting compressed air lines.

Always operate the ACS3920 Air Compressor System in a clean, dry, well-ventilated area, free of combustible materials, or solvent vapors. Operate in an open area at least 12 inches away from any wall or obstruction that would restrict the flow of fresh air to the ventilation openings. Restricting any of the housing openings will cause serious overheating leading to probable failure or possible fire.

The ACS3920 Air Compressor System is an electrically powered device. Never operate in wet conditions and never operate with cover removed. Failure to provide adequate grounding could result in serious injury or death from electrocution. Make certain that the electrical circuit provides proper electrical grounding, correct voltage, and adequate fuse protection.

Attempting to operate the ACS3920 with damaged or missing parts or attempting to repair with protective cover removed can expose you to moving parts and can result in serious injury. Any repair required should be performed by authorized personnel. Repairs attempted by unqualified personnel can result in serious injury or death by electrocution.

The compressed air from the ACS3920 is not safe for breathing and should never be used to supply air for human consumption. The compressed air will contain less oxygen than normal air and will not meet breathing air standards for oxygen content. The air stream may also contain carbon monoxide, toxic vapors, or solid particles. Breathing these contaminants can cause serious injury or death.

Always operate the ACS3920 in a stable secure position to prevent accidental movement of the unit.

Refer to Gast Manufacturing 71R Series Rocking Piston Oil-Less Pump Operating and Maintenance Manual for additional specifications, service instructions, safety guidelines, hazard, and warning information.

4 INSTALLATION

4.1 Unpacking

Unpack the ACS3920 Air Compressor System carefully and inspect it for any damage that may have occurred during shipment. If there is shipping damage, notify the carrier immediately. Verify that the power cord, air supply tubing with connection fittings, and operation manual are present. If possible, save shipping container for future use.

4.2 Location

Locate the ACS3920 on the floor with the outlet within 6 feet of the 3920 generator's gas inlet and at least 12 inches away from the wall or other obstructions that would restrict the flow of air to or from the ventilation openings. The enclosure is designed to allow for proper cooling therefore ventilation openings must remain unrestricted to maintain proper operating temperature.

4.3 Air Supply Tubing

Connect the 1/8" OD air supply tubing between the ACS3920 outlet and the humidity generator's gas inlet. The VCR type fitting connections require that face seal gaskets must be used.

4.4 Power

The ACS3920 is equipped with a power receptacle (RCP1) and cord having a grounding wire with an appropriate grounding plug. The plug must be used with an outlet that has the same configuration and has been installed and grounded in accordance with all local codes and ordinances.

Power of the appropriate voltage, frequency, and current capacity, as indicated on the equipment label, is applied via the power cord to the ACS3920 power receptacle.

4.5 Remote-Control ACS Cable

This cable is used only if the 3920 Low Humidity Generator is configured with the Remote-Control ACS option.

If configured, connect the ACS1 control cable between the humidity generator and the ACS3920 Air Compressor System. This will allow the humidity generator to start and stop the air compressor when required for humidity generation operation.

5 COMPONENTS and CONTROLS

Refer to paragraph 5.10 for Component Locations

5.1 Power Switch

The Power Switch (CBS1) allows power to be turned on or off at this location independent from the humidity generator. The Power Switch also has a built-in circuit breaker for protection of the ACS3920 air compressor system.

5.2 Remote/Manual Operation Switch

The Remote/Manual Switch (S1) allows the operator to select between Manual and Remote-Control operation of the ACS3920. In Manual mode the air compressor will run continuously until the main Circuit Breaker Switch (CBS1) is toggled off. In remote mode the air compressor is controlled by the humidity generator if configured with the Remote-Control ACS option.

Caution: Do not toggle "Remote/Manual" switch (S1) when compressor is running. Use On/Off Circuit Breaker Switch (CBS1) to stop and then toggle "Remote/Manual" switch to change operating modes.

5.3 Hour Meter

The Hour Meter (HM1) tracks total run hours of the ACS3920 air compressor system.

5.4 Air Compressor

The 3/4 HP Oil-less Air Compressor (COMP) provides oil-free air regulated (REG1) to a pressure of 140 psiG (G1) to the inlet of the membrane air dryer.

The Safety Valve (mounted on the compressor) protects the system against over pressure. Over pressure is indicated by the "popping off" sound of the safety valve.

Note: Compressor pressures higher than 140 psiG should be avoided. High pressures will shorten the life of the compressor and will be indicated by the "popping off" of the compressor safety valve.

5.5 Compressed Air Membrane Dryer

The Compressed Air Membrane Dryer (AD1) is located after the air compressor and is specifically designed to remove water vapor from the compressed air stream prior to the CO2 Adsorber/Dryer (AD2) inlet. The membrane dryer removes water vapor from the gas stream by the selective permeation of water molecules through polymer. Excess dry air from the inlet pressure regulator outlet (REG1), flows in a counter direction at low pressure on the permeate side, to purge water vapor from the shell side of the dryer which is then vented to atmosphere.

5.6 Inlet Pressure Regulator

The Inlet Pressure Regulator (REG1) controls the pressure available from the membrane dryer, indicated on pressure gauge G1, to the CO2 Adsorber/Dryer inlet regulator (REG2).

Turn the 9/32" (7mm) adjustment shaft on the inlet pressure regulator clockwise to increase pressure and counterclockwise to decrease pressure. Set the pressure to 140 psiG as indicated on pressure gauge G1.

Note: Adjustment may be necessary after one hour of run time to keep the indicated pressure at 140 psiG (G1).

5.7 CO2 Adsorber/Dryer Inlet Pressure Regulator

The CO2 Adsorber/Dryer Inlet Pressure Regulator (REG2) controls the pressure available from the membrane dryer to the CO2 Adsorber/Dryer inlet, as indicated on pressure gauge (G2). This pressure is factory set to 120 psiG as indicated on pressure gauge (G2) and should not require adjustment.

5.8 Outlet Pressure Regulator

The Outlet Pressure Regulator (REG3) controls the pressure available from the CO2 Adsorber/Dryer outlet to the ACS3920 outlet and is indicated on pressure gauge G3. This pressure is factory set to the maximum outlet pressure of 100 psiG as indicated on the pressure gauge and should not require adjustment. If a lower outlet pressure is desired, rotate the regulator knob counterclockwise until the desired outlet pressure is reached.

5.9 Dimensional Drawing

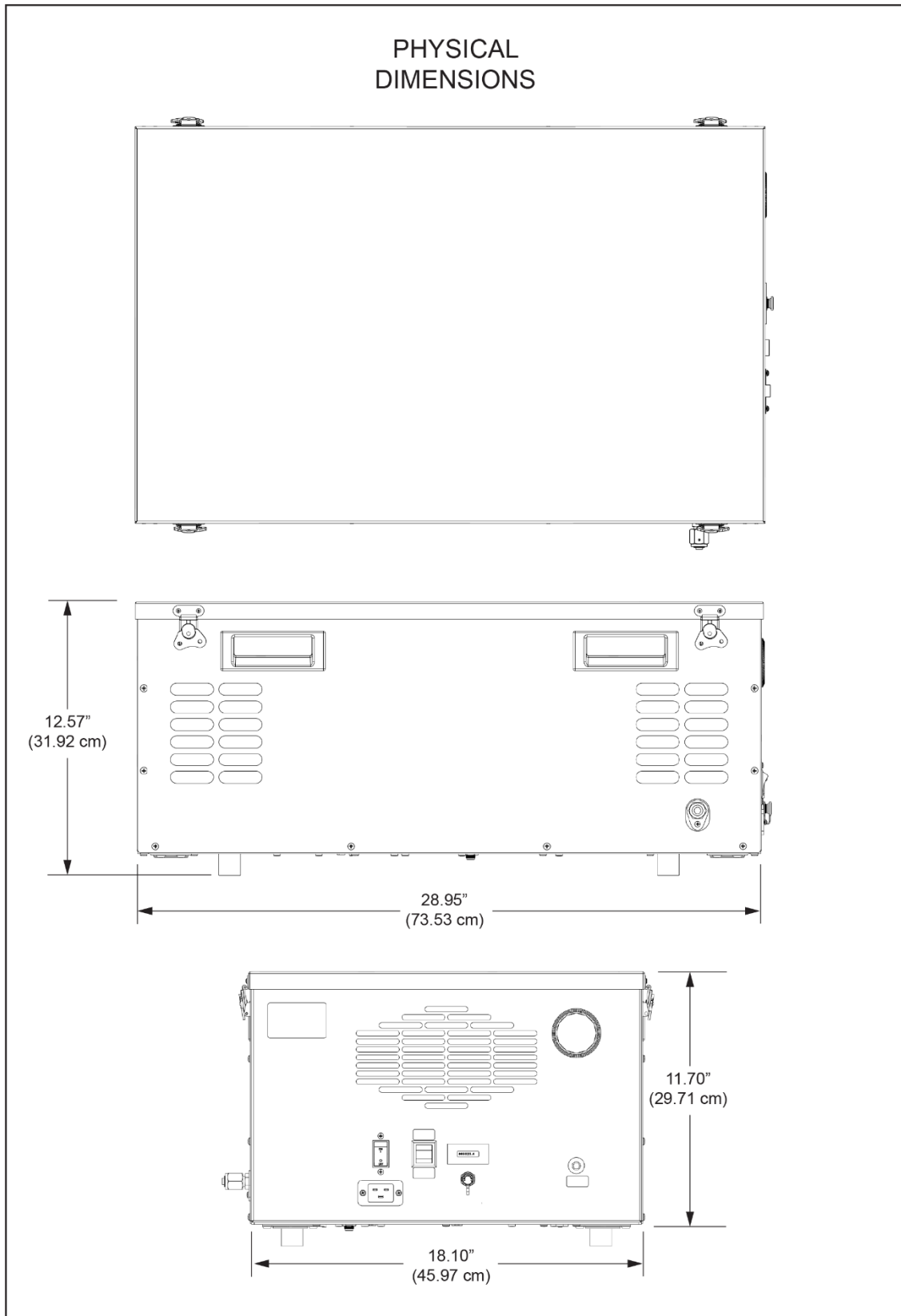

5.10 Component Locations

ITEM DESCRIPTION

1. Air Outlet
2. Air Dryer / Membrane (AD1)
3. Air Dryer / CO2 Adsorber (AD2)
4. On / Off Circuit Breaker Switch (CBS1)
5. Circulation Fan (CF1)
6. Circulation Fan (CF2)
7. Air Compressor (COMP)
8. Check Valve (CV1)
9. Air Intake Filter (F1)
10. Pressure Gauge (G1)
11. Pressure Gauge (G2)
12. Pressure Gauge (G3)
13. Heat Limit Switch (HLS)

ITEM DESCRIPTION

14. Hour Meter (HM1)
15. Remote Power Jack (J1)
16. Particulate Filter (LF1)
17. Particulate Filter (LF2)
18. Particulate Filter (LF3)
19. Particulate Filter (LF4)
20. Power Receptacle (RCP1)
21. Pressure Regulator (REG1)
22. Pressure Regulator (REG2)
23. Pressure Regulator (REG3)
24. Remote/Manual Switch (S1)
25. Solenoid Valve (SOL1)

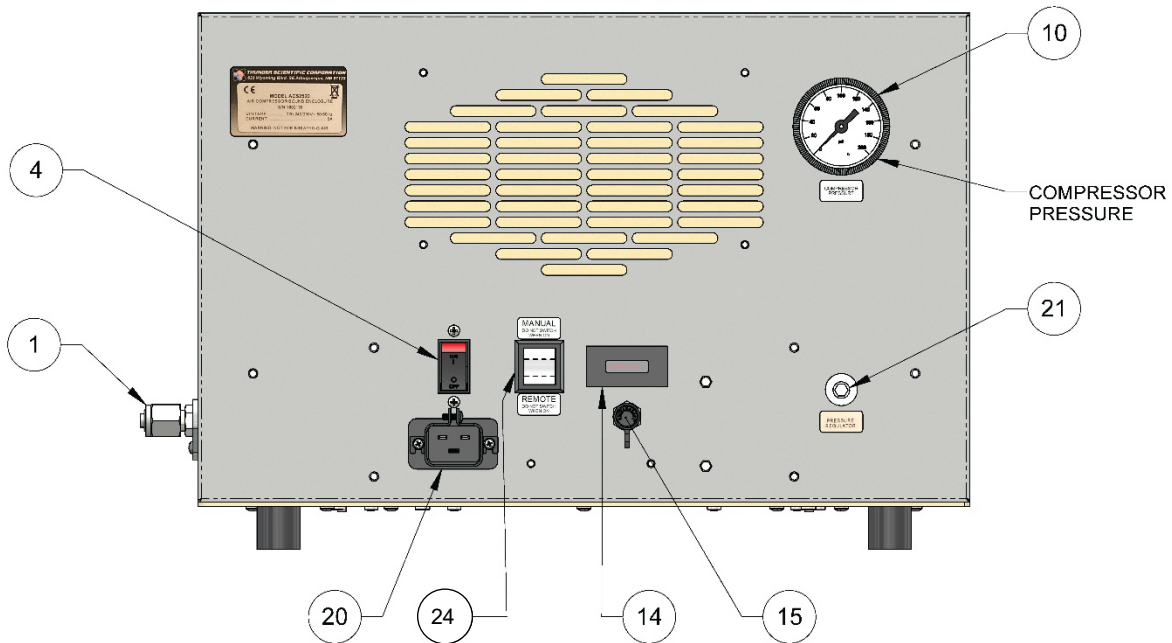

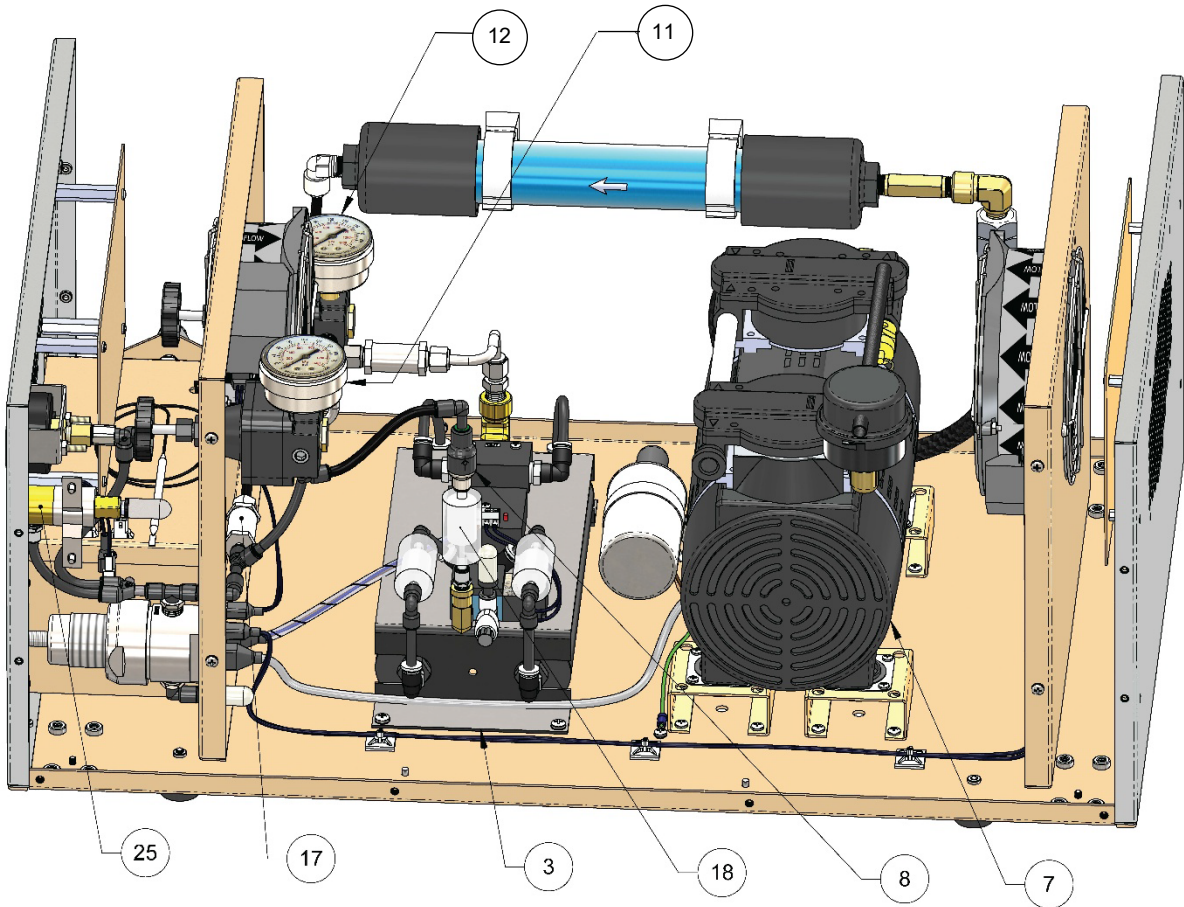
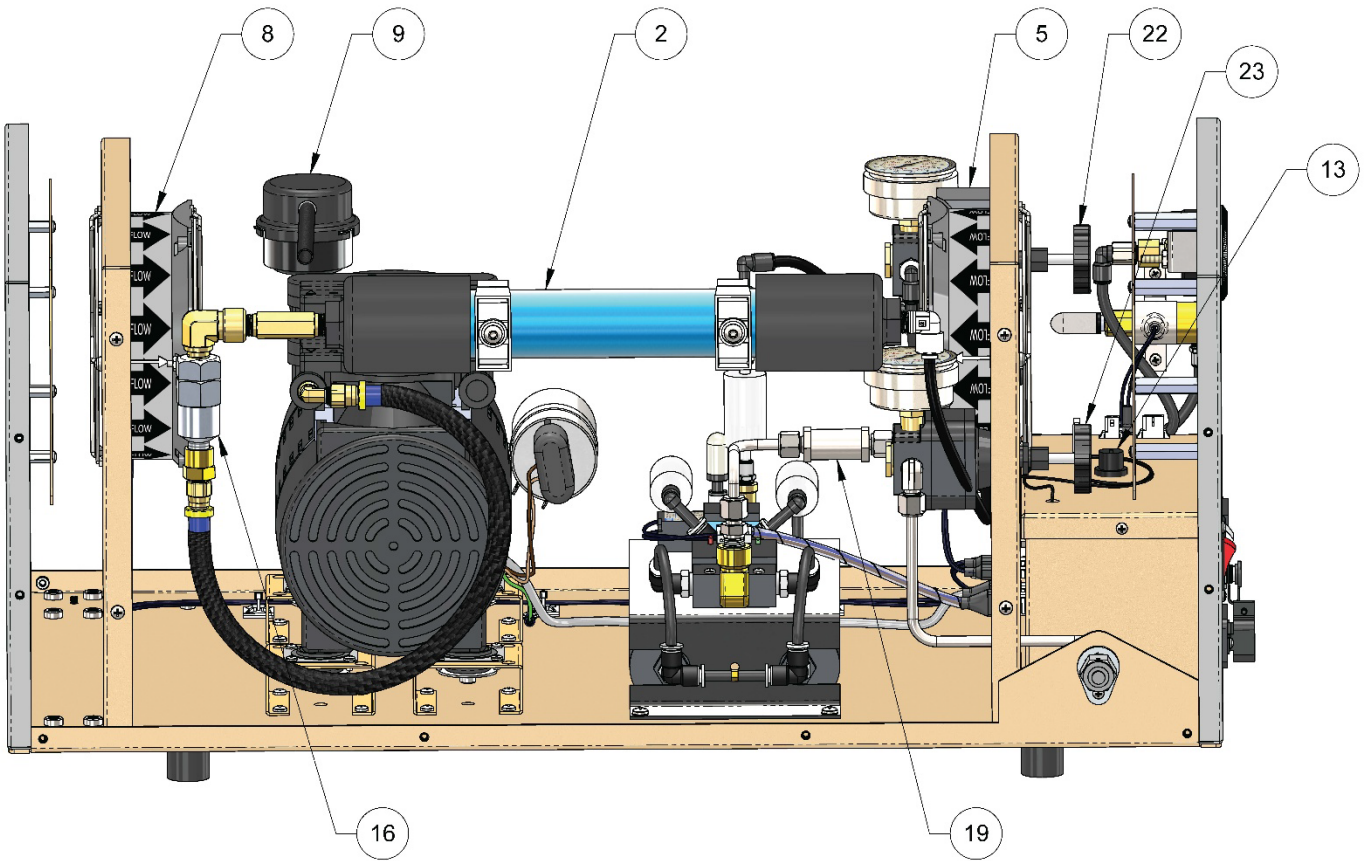

6 GENERAL OPERATION

6.1 Start-up

Be sure the "Air Supply Tubing" installation of paragraph 4.3 has been completed before proceeding.

Insert the power cord into the ACS3920 power receptacle. With the ACS3920 circuit breaker power switch in the off position, plug the power cord into an AC mains outlet of the appropriate voltage, frequency, and current capacity as indicated by the equipment label.

Using the Remote/Manual switch (S1); select "Manual" to allow the air compressor system to run continuous. Apply power to the ACS3920 using the On/Off circuit breaker power switch (CBS1). The compressor will start immediately, and the pressure gauge (G1) will begin to indicate pressure of approximately 140 psiG.

Caution: Do not toggle "Remote/Manual" switch (S1) when compressor is running. Use On/Off Circuit Breaker Switch (CBS1) to stop the compressor and then toggle "Remote/Manual" switch to change operating modes.

6.2 Input Pressure Adjustment

If input pressure adjustment is required adjust the input pressure regulator (REG1) to 140 psiG, during no-flow conditions. Turn the 9/32" (7mm) adjustment shaft clockwise to increase pressure and counterclockwise to decrease pressure.

6.3 Shutdown

Disconnect power to the ACS3920 using the On/Off circuit breaker power switch.

Important: All pressure MUST be vented before disconnecting the air supply tubing or personal injury may result.

7 INSPECTION and MAINTENANCE

7.1 Recommended Maintenance Schedule

<u>Periodic Maintenance</u>	<u>Hours 100% Duty Cycle</u>
Initial Inlet Filter (F1) Inspection To establish service period	1,000
Minor Service Kit	2,000
Major Compressor Rebuild or Replacement	4,000
Replace MCA5 Desiccant Towers (If measured output is wet) 2ea Part Number 51385	4,000

Note: Refer to the MCA5 users guide for additional "Inspection and Maintenance" information.

7.2 Filter Inspection and Replacement

The Intake Filter requires periodic inspection. Initial inspection is suggested at 1,000 hours; then user should determine the frequency thereafter. Most problems can be prevented by keeping the intake filter clean. A dirty intake filter will decrease compressor performance and can decrease compressor life.

Warning: Disconnect power and be sure all pressure has been vented before service!

1. Intake Filter (F1)
 - a. Remove ACS3920 top access cover.
 - b. Remove intake filter cover by pushing in and turning clockwise.
 - c. Clean or replace the filter using air or vacuum.
 - d. Replace cover by pushing in and turning counterclockwise.

2. Particulate Filter (LF1) Clean or replace element at 4,000 hours.
 - a. Remove ACS3920 top access cover.
 - b. Open membrane dryer retainer clips.
 - c. Lift compressor end of membrane dryer for access to filter.
 - d. Disconnect compressor outlet hose from filter inlet.
 - e. Remove the filter assembly from membrane dryer using a backup wrench on inlet elbow.
 - f. Unscrew the adapter (1) by turning counterclockwise.
 - g. Remove filter (3) and replace or clean with water and blow dry.
 - h. Inspect bowl (5) and seal (4). If dirty, clean by wiping the bowl with a soft dry cloth.
 - i. Ensure seal (2) is clean and in place then re-install filter and rotate the adapter clockwise until snug.
 - j. Re-install filter assembly using a backup wrench on inlet elbow turning clockwise.
 - k. Reconnect compressor outlet hose to filter inlet.
 - l. Snap membrane dryer back into place.

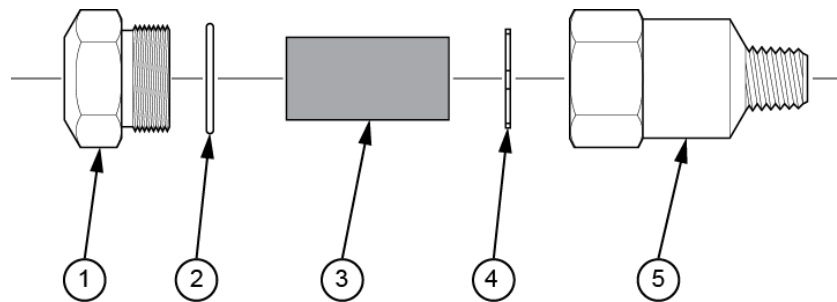

Particulate Filter (LF1)

7.3 Storage Procedures

Proper shutdown procedures must be followed to prevent pump damage. Failure to do so may result in premature compressor failure. The non-lubricated compressor is constructed of ferrous metals and/or aluminum which are treated for corrosion protection but are still subject to possible rust and corrosion when pumping condensable vapors such as water.

Follow the steps below to assure correct shutdown and storage between uses:

1. **NEVER** oil this non-lubricated compressor as damage will result.
2. For long term storage of the ACS3920:
 - a. Disconnect power from ACS3920.
 - b. Remove ACS3920 top access cover.
 - c. Disconnect the air hose at the outlet of the compressor.
 - d. Apply power and run the compressor "open" for at least five minutes.
 - e. Disconnect power and cap outlet to prevent contaminants from entering.
 - f. The ACS3920 is now ready for long term storage.

7.4 Service Kit

Refer to Gast Manufacturing 71R Series Rocking Piston Oil-Less Pump Operating and Maintenance Manual for parts and procedures.

7.5 Heat Limit Switch

The non-recycling heat limit switch (HLS) trips at a predetermined set point shutting down the circuit until reactivated. This switch is tripped in the event of elevated temperature above the maximum operating temperature.

To reactivate limit switch:

- a. Disconnect power from ACS3920.
- b. Remove ACS3920 top access cover.
- c. Locate and remove the black slotted limit switch cap (13).
- d. Press the reset button (under black cap).
- e. Replace black slotted cap.
- f. Replace the ACS3920 top access cover.

8 SCHEMATICS

8.1 Pneumatic Schematic

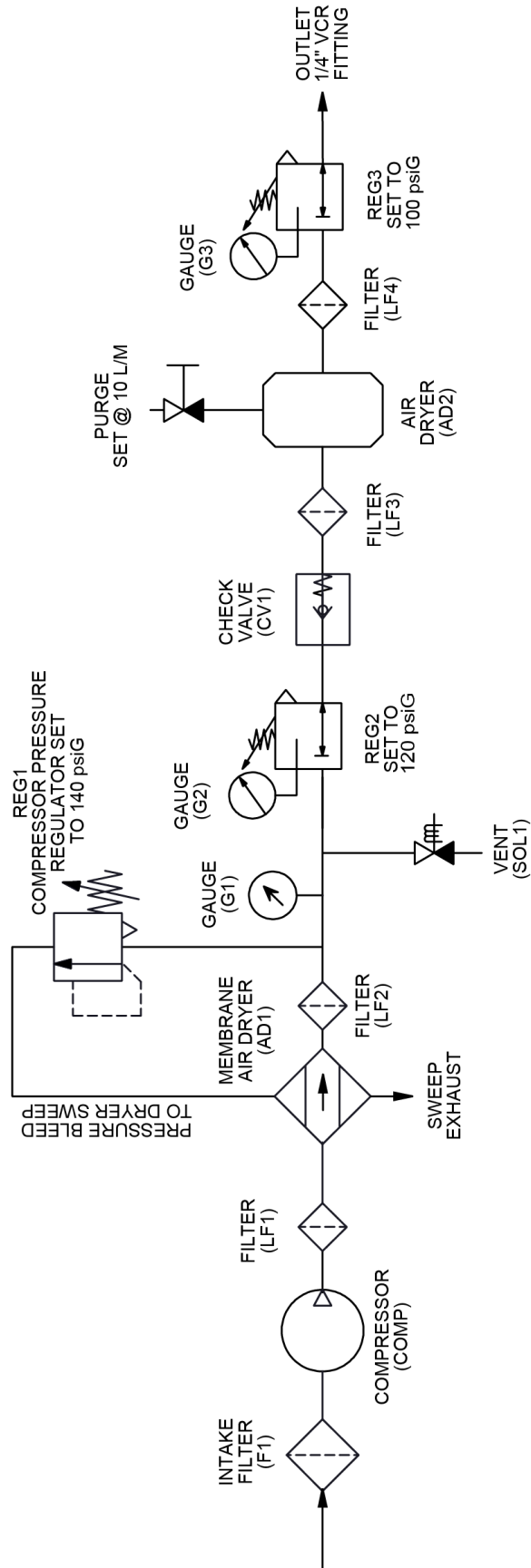

8.2 Electrical Schematic 110 VAC

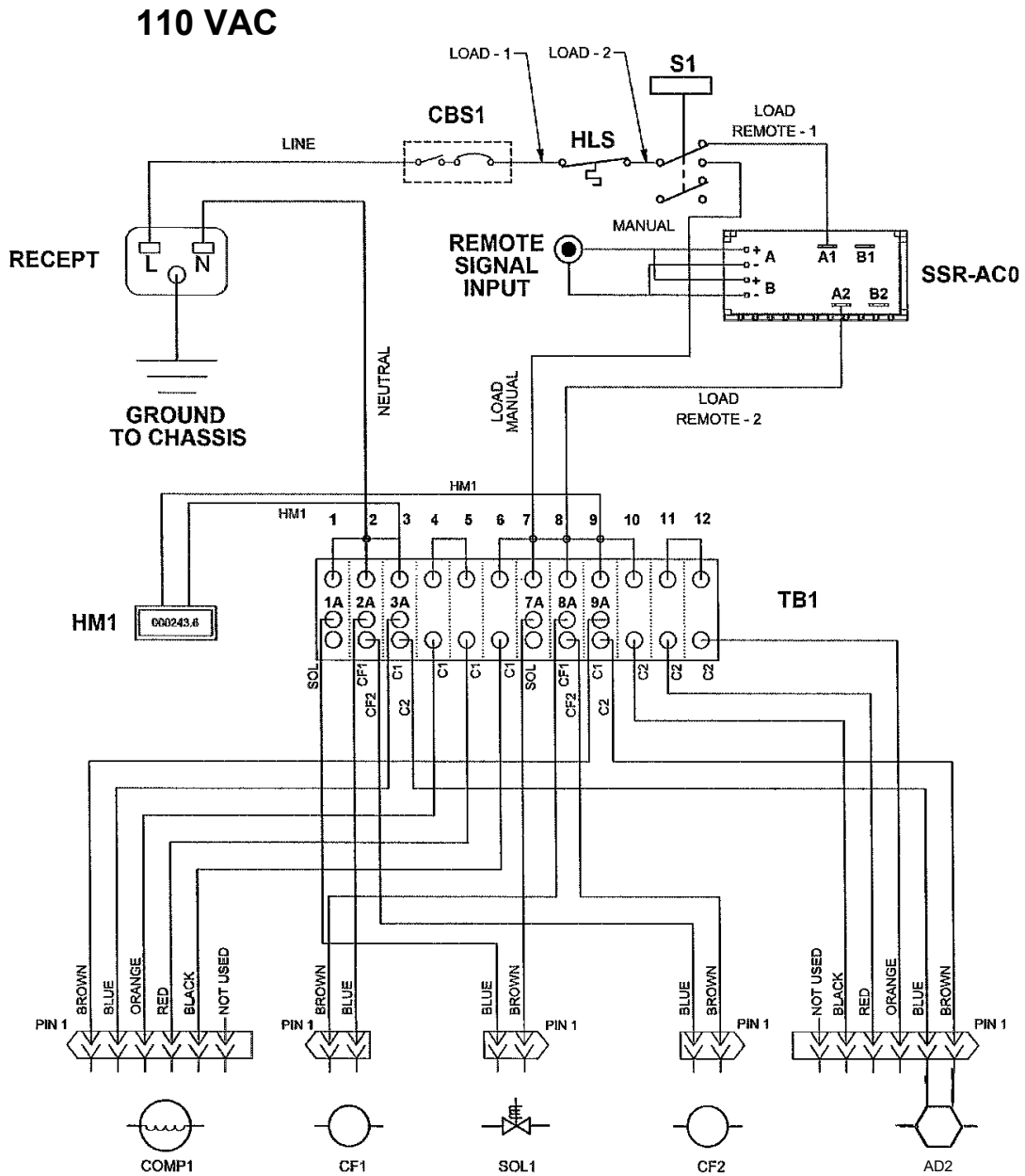

Figure 1-2

Figure 1-2

9 TROUBLESHOOTING GUIDE

Possible Reason	No / Low Pressure	High Pressure	Excessive Noise	Over Heating	Won't Start	Wet Output
Dirty Intake Filter (LF1)	X					X
Dirty Particulate Filter (LF1)	X					X
Hose Leak	X					X
Regulator Adjustment	X	X	X			
Worn or Damaged Compressor	X		X		X	X
Worn or Damaged Fan			X	X		
Safety Valve "Popping Off"		X	X			
Low Voltage				X	X	
Blocked Ventilation Opening	X		X	X	X	X
High Outlet Pressure					X	
Overheating	X	X	X	X	X	X
Heat Limit Switch Tripped				X	X	
Excessive Flow Rate						X
Desiccant Towers (End of Life)						X

Note: Refer to the MCA6 users guide for additional trouble shooting for a "Wet Output"

10 PARTS LIST

Find #	Qty	Description	Part Number
CBS1	1	Circuit Breaker Switch	ACSPWRSW-1
HM1	1	Hour Meter	HRMETERACS
S1	1	Switch, Remote/Manual	RGSC D901RWB0
J1	1	Jack, Remote Control	L722AS
COMP	1	Compressor	71R555-P322-N570X
G1	1	Gauge, Pressure	G1X510
G2 & 3	2	Gauge, Pressure	G6X114
REG1	1	Regulator, Back Pressure	JBPREG
REG2 & 3	2	Regulator	REGNG200
AD1	1	Air Dryer, Membrane	AirDryer100
AD2	1	CO2 Adsorber/Dryer	MCA6-11
CF1&2	2	Fan, Circulation	MR2B3
F1	1	Filter, Air Intake	5Z768
LF1	1	Filter, Particulate Line	FRP-95-199
LF2	1	Filter, Particulate Line	S4F-T7-7
LF3 & 4	2	Filter, Particulate Line	4HEU8
CV1	1	Valve, Check	7996-56-00
SOL1	1	Valve, Solenoid	U147121-110
SSR-AC0	1	Relay, Solid State UPD Dual Output	UPD2415DF
HLS	1	Switch, Heat Limit	CAP-MR-140-SS

This Page Intentionally
Left Blank

71R & 72R SERIES ROCKING PISTON OIL-LESS PUMPS

OPERATION & MAINTENANCE MANUAL



Single Cylinder Model Shown



Twin Cylinder Model Shown

Thank you for purchasing this Gast product. It is manufactured to the highest standards using quality materials. Please follow all recommended maintenance, operational and safety instructions and you will receive years of trouble free service.



WARNING



PLEASE READ THIS MANUAL COMPLETELY BEFORE INSTALLING AND USING THIS PRODUCT. SAVE THIS MANUAL FOR FUTURE REFERENCE AND KEEP IN THE VICINITY OF THE PRODUCT.

Product Use Criteria:

- Pump only clean, dry air.
- Operate at 32°F - 104°F (0°C - 40°C).
- Protect unit from dirt & moisture.
- Do not pump flammable or explosive gases or use in an atmosphere that contains such gases.
- Protect all surrounding items from exhaust air. This exhaust air can become very hot.
- Corrosive gases and particulate material will damage unit. Water vapor, oil-based contaminants or other liquids must be filtered out.
- Consult your Gast Distributor/Representative before using at high altitudes.
- This pump is oil-less and requires NO lubrication.



ISO 9001 & 14001 CERTIFIED

www.gastmfg.com

Your safety and the safety of others is extremely important.

We have provided many important safety messages in this manual and on your product. Always read and obey all safety messages.



This is the safety alert symbol. This symbol alerts you to hazards that can kill or hurt you and others. The safety alert symbol and the words “DANGER” and “WARNING” will precede all safety messages. These words mean:

DANGER

You **will** be killed or seriously injured if you don't follow instructions.

WARNING

You **can** be killed or seriously injured if you don't follow instructions.

All safety messages will identify the hazard, tell you how to reduce the chance of injury, and tell you what can happen if the safety instructions are not followed.

INSTALLATION

WARNING



Electrical Shock Hazard

Disconnect electrical power at the circuit breaker or fuse box before installing this product.

Install this product where it will not come into contact with water or other liquids.

Install this product where it will be weather protected.

Electrically ground this product.

Failure to follow these instructions can result in death, fire or electrical shock.

Correct installation is your responsibility. Make sure you have the proper installation conditions and that installation clearances do not block air flow.

Blocking air flow over the product in any way can cause the product to overheat.

Mounting

This product can be installed in any orientation. Mounting the product to a stable, rigid operating surface and using shock mounts will reduce noise and vibration.

Plumbing

Remove plugs from the IN and OUT ports. Connect with pipe and fittings that are the same size or larger than the product's threaded ports. Be sure to connect the intake and exhaust plumbing to the correct inlet and outlet ports. Ports will not support plumbing.

Accessories

The product's external intake and exhaust muffler will provide adequate filtration in most applications. Check filters periodically and replace when necessary. Consult your Gast Distributor/Representative for additional filter recommendations.

Install relief valves and gauges at inlet or outlet or both, to monitor performance. Check valves may be required to prevent back streaming through the pump.

Motor Control

It is your responsibility to contact a qualified electrician and assure that the electrical installation is adequate and in conformance with all national and local codes and ordinances. The metal capacitor must be grounded.

Determine the correct overload setting required to protect the motor (see motor starter manufacturer's recommendations). Select fuses, motor protective switches or thermal protective switches to provide protection. Fuses act as short circuit protection for the motor, not as protection against overload. Incoming line fuses must be able to withstand the motor's starting current. Motor starters with thermal magnetic overload or circuit breakers protect motor from overload or reduced voltage conditions.

The wiring diagram supplied with the product provides required electrical information. Check that power source is correct to properly operate the dual-voltage motors.

Electrical Connection

WARNING

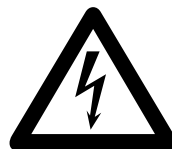

Electrical Shock Hazard

This product must be properly grounded.

Do not modify the plug provided. If it will not fit the outlet, have the proper outlet installed by a qualified electrician.

If repair or replacement of the cord or plug is necessary, do not connect the grounding wire to either flat blade terminal. The wire with insulation that is green or green with yellow stripes is the grounding wire.

Check the condition of the power supply wiring. Do not permanently connect this product to wiring that is not in good condition or is inadequate for the requirements of this product.

Failure to follow these instructions can result in death, fire or electrical shock.

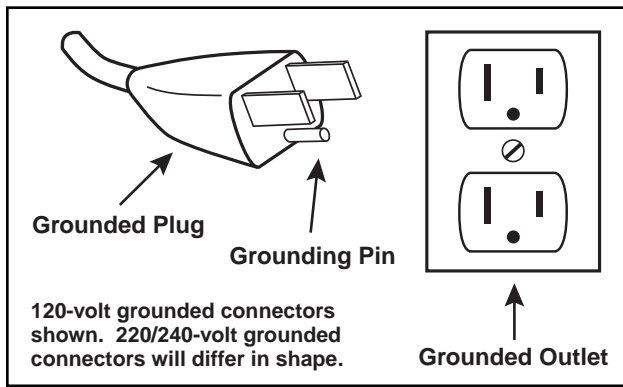

Model with a power supply cord:

This product must be grounded. For either 120-volt or 220/240-volt circuits connect power supply cord grounding plug to a matching grounded outlet. Do not use an adapter. (See above diagram.)

In the event of an electrical short circuit, grounding reduces the risk of electric shock by providing an escape wire for the electric current. This product may be equipped with a power supply cord having a grounding wire with an appropriate grounding plug. The plug must be plugged into an outlet that is properly installed and grounded in accordance with all local codes and ordinances.

Check with a qualified electrician or serviceman if the grounding instructions are not completely understood, or if you are not sure whether the product is properly grounded. Do not modify the plug provided. If it will not fit the outlet, have the proper outlet installed by a qualified electrician.

Model that is permanently wired:

This product must be connected to a grounded, metallic, permanent wiring system, or an equipment grounding terminal or lead on the product.

Power supply wiring must conform to all required safety codes and be installed by a qualified person. Check that supply voltage agrees with that listed on product nameplate.

Extension cords:

Use only a 3-wire extension cord that has a 3-blade grounding plug. Connect extension cord plug to a matching 3-slot receptacle. Do not use an adapter. Make sure your extension cord is in good condition. Check that the gage wire of the extension cord is the correct size wire to carry the current this product will draw.

An undersized cord is a potential fire hazard, and will cause a drop in line voltage resulting in loss of power causing the product to overheat. The following table indicates the correct size cord for length required and the ampere rating listed on the product nameplate. **If in doubt, use the next heavier gage cord. The smaller the gage number, the heavier the wire gage.**

Minimum gage for extension cords										
Amps	Volts	Length of cord in feet								
	120v	25	50	100	150	200	250	300	400	500
	240v	50	100	200	300	400	500	600	800	1000
0-2		18	18	18	16	16	14	14	12	12
2-3		18	18	16	14	14	12	12	10	10
3-4		18	18	16	14	12	12	10	10	8
4-5		18	18	14	12	12	10	10	8	8
5-6		18	16	14	12	10	10	8	8	8
6-8		18	16	12	10	10	8	6	6	6
8-10		18	14	12	10	8	8	6	6	4
10-12		16	14	10	8	8	6	6	4	4
12-14		16	12	10	8	6	6	6	4	2
14-16		16	12	10	8	6	6	4	4	2
16-18		14	12	8	8	6	4	4	2	2
18-20		14	12	8	6	6	4	4	2	2

OPERATION

! WARNING

Injury Hazard
Install proper safety guards as needed.
Keep fingers and objects away from openings and rotating parts.
When provided, motor terminal covers must be in place for safe operation.
Product surfaces become very hot during operation, allow product surfaces to cool before handling.
Air stream from product may contain solid or liquid material that can result in eye or skin damage, wear proper eye protection.
Wear hearing protection. Sound level from motor may exceed 70 dBA.
Failure to follow these instructions can result in burns, eye injury or other serious injury.

It is your responsibility to operate this product at recommended pressures or vacuum duties and room ambient temperatures. Do not start against a vacuum or pressure load.

Start Up
 If motor fails to start or slows down significantly under load, shut off and disconnect from power supply. Check that the voltage is correct for motor and that motor is turning in the proper direction. Check the plug, cord and switch for damage. If so equipped, the thermal protection switch has tripped, the motor can restart after cooling.

MAINTENANCE

WARNING



Electrical Shock Hazard

Disconnect electrical power supply cord before performing maintenance on this product.

If product is hard wired into system, disconnect electrical power at the circuit breaker or fuse box before performing maintenance on this product.

Failure to follow these instructions can result in death, fire or electrical shock.

WARNING

Injury Hazard

Product surfaces become very hot during operation, allow product surfaces to cool before handling.

Air stream from product may contain solid or liquid material that can result in eye or skin damage, wear proper eye protection.

Clean this product in a well ventilated area.

Failure to follow these instructions can result in burns, eye injury or other serious injury.

It is your responsibility to:

- Regularly inspect and make necessary repairs to product in order to maintain proper operation.
- Make sure that pressure is released from product before starting maintenance.

Check intake and exhaust filters after first 500 hours of operation. Clean filters and determine how frequently filters should be checked during future operation. This one procedure will help to assure the product's performance and service life.

1. Remove filter cover.
2. Remove filters and felt (some filters are held together with a snap fitting). Clean filters by washing in a non-petroleum based solvent or soap and water. After cleaning, dry with compressed air to make sure all moisture is removed before reinstalling filters.
3. Reinstall felt and filters.
4. Reinstall cover.

Check that all external accessories such as relief valves and gauges are attached to cover and are not damaged before re-operating product.

SHUTDOWN PROCEDURES

It is your responsibility to follow proper shutdown procedures to prevent product damage. NEVER ADD OIL TO THIS OIL-LESS PUMP.

Proper shutdown procedures must be followed to prevent pump damage. Failure to do so may result in premature pump failure. Gast Manufacturing Rocking Piston Oil-Less Pumps are constructed of ferrous metals or aluminum which are subject to rust and corrosion when pumping condensable vapors such as water. Follow the steps below to assure correct storage and shutdown between operating periods.

1. Disconnect plumbing.
2. Operate product for at least 5 minutes without plumbing.
3. Run at maximum vacuum for 10 to 15 minutes.
4. Repeat step 2.
5. Disconnect power supply.
6. Plug open ports to prevent dirt or other contaminants from entering product.

SERVICE KIT INSTALLATION

WARNING

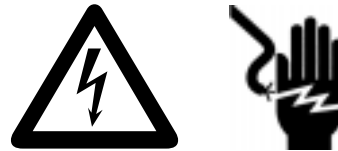

Electrical Shock Hazard

Disconnect electrical power supply cord before installing Service Kit.

If product is hard wired into system, disconnect electrical power at the circuit breaker or fuse box before installing Service Kit.

Vent all air lines to release pressure or vacuum.

Failure to follow these instructions can result in death, fire or electrical shock.

Gast will NOT guarantee field-rebuilt product performance. For performance guarantee, the product must be returned to a Gast Authorized Service Facility.

Service Kit contents vary. Most contain gasket and filter parts.

1. Disconnect electrical power to pump.
2. Disconnect air supply and vent all air lines to release pressure or vacuum.
3. Mark the orientation of the ports so cover will be reinstalled correctly.
4. Remove screws from the head of the pump. Remove the head of the pump.
5. Mark orientation of valve plate(s). Remove valve plate(s).
6. Remove and discard old cups(s), retainer screws, cylinder O-ring(s), head O-ring(s), valves and valve retainers.
7. Install new cup(s) on rod(s) facing up.
8. Reinstall retainer plates.
9. Apply a thread locking compound (Loctite 222) to retainer screws. Torque screws to 34-38 in. lbs.
10. Carefully install cylinder(s) over cup(s) at an angle to avoid damaging cup(s).
11. Clean valve plates with water based solvent. Take care to not scratch valve seats.
12. Install valves and valve retainers. Check that the orientation with the ports is correct.
13. Apply a thread locking compound (Loctite 222) to retainer screws. Torque screws to 10-13 in. lbs.
14. Install cylinder O-ring(s) in the bottom of valve plate(s).
15. Check that the orientation of valve plate(s) with the ports is correct.
16. Install head O-rings in the O-ring grooves on top of valve plate.
17. Reinstall head over valve plate(s) checking that orientation with ports is correct.
18. Torque screws to 50 in. lbs.

Check that all external accessories such as relief valves and gauges are not damaged before re-operating product.

If pump still does not produce proper vacuum or pressure, send unit to a Gast Authorized Service Facility for repair.

WARRANTY

Gast finished products, when properly installed and operated under normal conditions of use, are warranted by Gast to be free from defects in material and workmanship for a period of twelve (12) months from the date of purchase from Gast or an authorized Gast Representative or Distributor. In order to obtain performance under this warranty, the buyer must promptly (in no event later than thirty (30) days after discovery of the defect) give written notice of the defect to Gast Manufacturing Incorporated, PO Box 97, Benton Harbor Michigan USA 49023-0097 or an authorized Service Center (unless specifically agreed upon in writing signed by both parties or specified in writing as part of a Gast OEM Quotation). Buyer is responsible for freight charges both to and from Gast in all cases.

This warranty does not apply to electric motors, electrical controls, and gasoline engines not supplied by Gast. Gast's warranties also do not extend to any goods or parts which have been subjected to misuse, lack of maintenance, neglect, damage by accident or transit damage.

THIS EXPRESS WARRANTY EXCLUDES ALL OTHER WARRANTIES OR REPRESENTATIONS EXPRESSED OR IMPLIED BY ANY LITERATURE, DATA, OR PERSON. GAST'S MAXIMUM LIABILITY UNDER THIS EXCLUSIVE REMEDY SHALL NEVER EXCEED THE COST OF THE SUBJECT PRODUCT AND GAST RESERVES THE RIGHT, AT ITS SOLE DISCRETION, TO REFUND THE PURCHASE PRICE IN LIEU OF REPAIR OR REPLACEMENT.

GAST WILL NOT BE RESPONSIBLE OR LIABLE FOR INDIRECT OR CONSEQUENTIAL DAMAGES OF ANY KIND, however arising, including but not limited to those for use of any products, loss of time, inconvenience, lost profit, labor charges, or other incidental or consequential damages with respect to persons, business, or property, whether as a result of breach of warranty, negligence or otherwise. Notwithstanding any other provision of this warranty, BUYER'S REMEDY AGAINST GAST FOR GOODS SUPPLIED OR FOR NON-DELIVERED GOODS OR FAILURE TO FURNISH GOODS, WHETHER OR NOT BASED ON NEGLIGENCE, STRICT LIABILITY OR BREACH OF EXPRESS OR IMPLIED WARRANTY IS LIMITED SOLELY, AT GAST'S OPTION, TO REPLACEMENT OF OR CURE OF SUCH NONCONFORMING OR NON-DELIVERED GOODS OR RETURN OF THE PURCHASE PRICE FOR SUCH GOODS AND IN NO EVENT SHALL EXCEED THE PRICE OR CHARGE FOR SUCH GOODS. GAST EXPRESSLY DISCLAIMS ANY WARRANTY OF MERCHANTABILITY OR FITNESS FOR A PARTICULAR USE OR PURPOSE WITH RESPECT TO THE GOODS SOLD. THERE ARE NO WARRANTIES WHICH EXTEND BEYOND THE DESCRIPTIONS SET FORTH IN THIS WARRANTY, notwithstanding any knowledge of Gast regarding the use or uses intended to be made of goods, proposed changes or additions to goods, or any assistance or suggestions that may have been made by Gast personnel.

Unauthorized extensions of warranties by the customer shall remain the customer's responsibility.

CUSTOMER IS RESPONSIBLE FOR DETERMINING THE SUITABILITY OF GAST PRODUCTS FOR CUSTOMER'S USE OR RESALE, OR FOR INCORPORATING THEM INTO OBJECTS OR APPLICATIONS WHICH CUSTOMER DESIGNS, ASSEMBLES, CONSTRUCTS OR MANUFACTURES.

This warranty can be modified only by authorized Gast personnel by signing a specific, written description of any modifications.

EXPLODED PRODUCT VIEW, PARTS & ORDERING INFORMATION

REF	DESCRIPTION	QTY	71R135-P001B	71R142-P001B	72R142-P001B
1	CAP SCREWS	4	BB570	BB570	BB570
2	HEAD	1	AT265G	AT265G	AT265
4 Δ	HEAD O-RING	1	AT258	AT258	AT258
5	HEX NUT	1	BC164	BC164	BC164
6 Δ	VALVE RETAINER	2	AF819A	AF819A	AF819A
7 Δ	LEAF VALVE	2	AF817	AF817	AF817
8	VALVE PLATE	1	AT631E	AT631E	AT281E
10	VALVE SCREW	1	BB330B	BB330B	BB330A
11 Δ	CYLINDER O-RING	1	AT256	AT256	AT276
12 Δ	CYLINDER	1	AT272	AT272	AT275
13 Δ	RETAINER SCREW	2	AT283	AT283	AT283
14	RETAINER PLATE	1	AT715	AT715	AT566A
15 Δ	PISTON CUP	1	AT329	AT329	AT280
16	ROD ASSEMBLY	1	AT526KZ	AT526GZ	AT527GZ
17	SHROUD	1	AT266	AT266	AT266
18	FAN	1	AT260A	AT260A	AT260A
19	SHROUD SCREW	4	AT261	AT261	AT261
20	VALVE PLATE ASSEMBLY	1	AT633K	AT633K	AT282K
***	FILTER	1	B300F	B300F	B300F
***	SERVICE KIT	1	K704	K704	K705

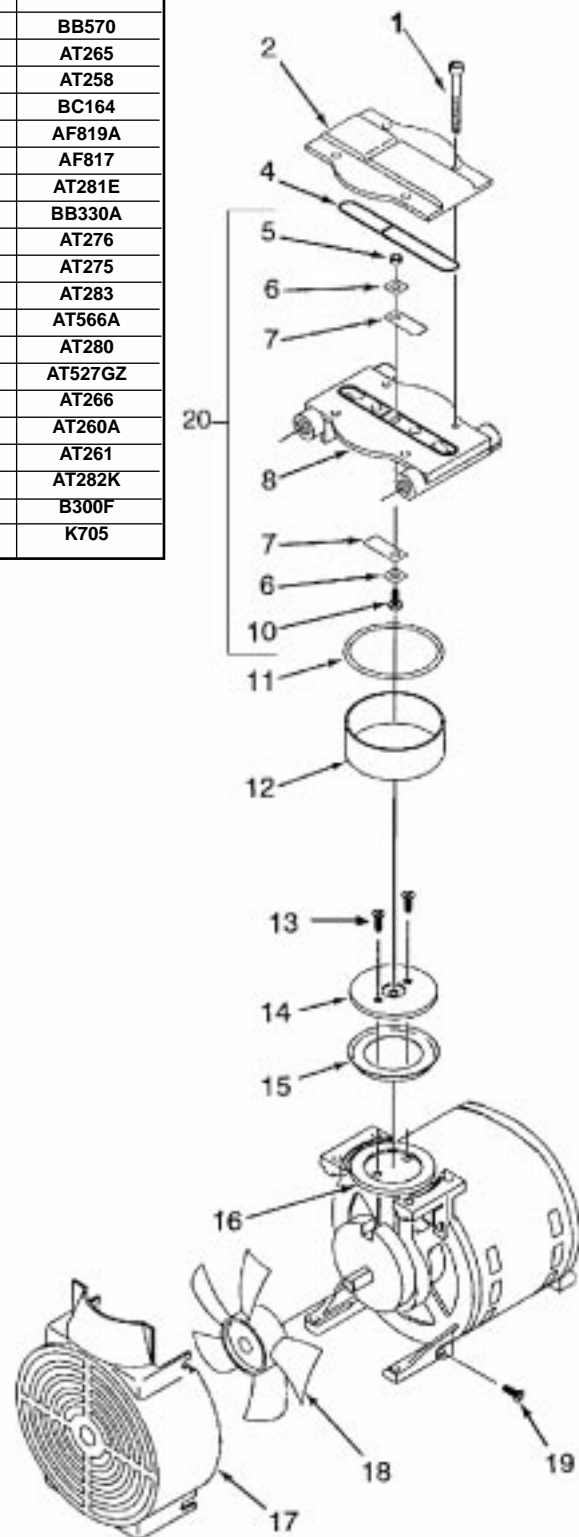

*** Item not shown.

Δ Denotes parts included in the Service Kit.

Parts listed are for stock models. For specific OEM models, please consult the factory.
When corresponding or ordering parts, please give complete model and serial numbers.

(FIG 1)
FOR MODELS 71R545-P315B
COVER/VALVE PLATE ASSM. SHOWN
SEPARATELY TO SHOW HIGH
PRESSURE END OF UNIT

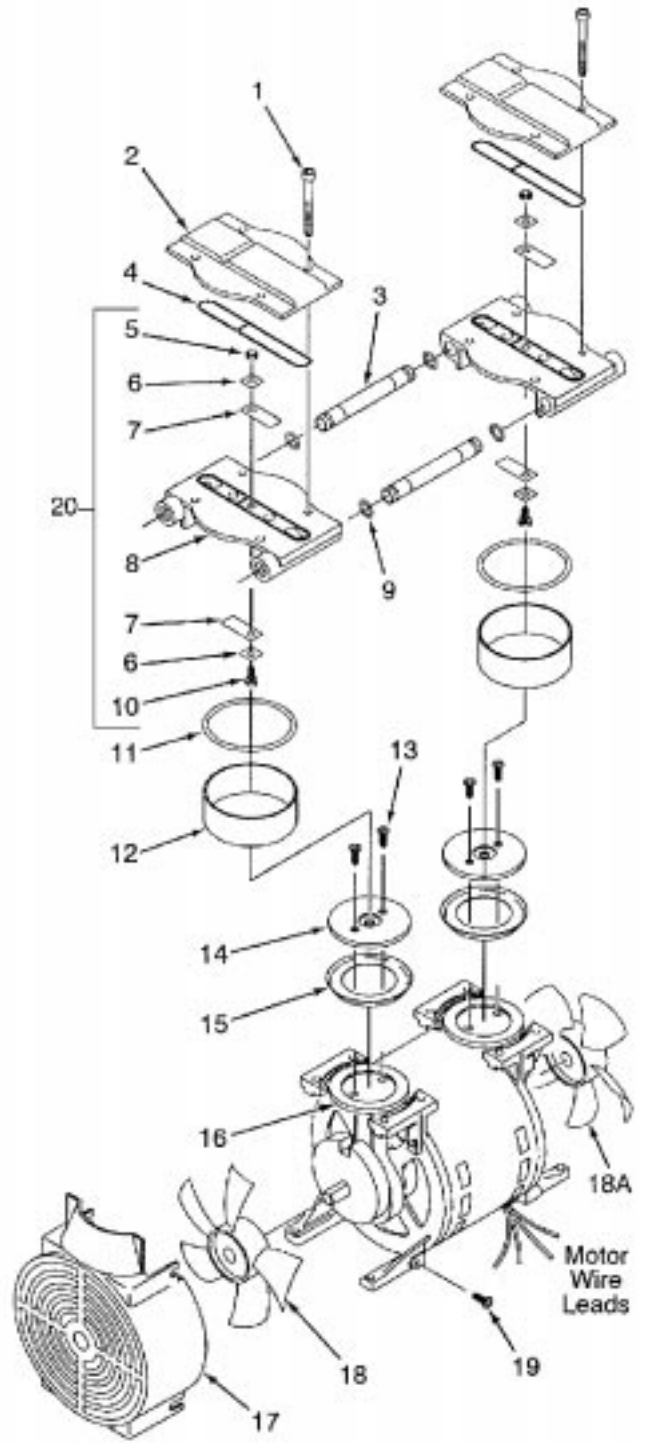
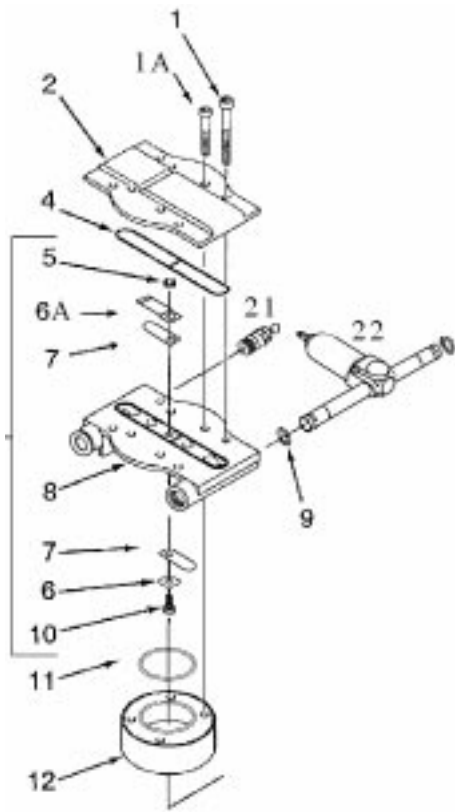

EXPLODED PRODUCT VIEW, PARTS & ORDERING INFORMATION

REF	DESCRIPTION	QTY	71R645-P112 71R645-V114	71R655-P112 71R655-V114	72R645-P112 72R645-V114	72R655-P112 72R655-V114	71R545-P315B
1	CAP SCREWS	8	BB570	BB570	BB570	BB570	(4) BB570
1A	CAP SCREWS	4					(4) BB614B
2	HEAD	2	AT265G	AT265G	AT265G	AT265G	(1) AT265G (1) AT265H
4 Δ	HEAD O-RING	2	AT258	AT258	AT258	AT258	AT258
5	HEX NUT	2	BC164	BC164	BC164	BC164	BC164
6 Δ	VALVE RETAINER	2	AF819A	AF819A	AF819A	AF819A	(3) AF819A
6A	VALVE LIMITER	1					(1) AH406
7 Δ	LEAF VALVE	2	AF817	AF817	AF817	AF817	(2) AF817 (2) AJ827A
8	VALVE PLATE	1	AT631	AT631	AT632	AT632	(1) AT631C (1) AT632X
9 Δ	TUBE O-RING	4	AK846	AK846	AK846	AK846	(2) AT528
10	VALVE SCREW	2	BB330	BB330	BB330	BB330	BB330B
11 Δ	CYLINDER O-RING	1	AT256	AT256	AT276	AT276	(1) AT256 (1) AJ787
12 Δ	CYLINDER	2	AT272	AT272	AT275	AT275	(1) AT272 (1) AT291
13 Δ	RETAINER SCREW	4	BB557	BB557	AT283	AT283	(2) AT283 (2) BB557
14	RETAINER PLATE	2	AT273	AT273	AT274C	AT274C	(1) AT715 (1) AT443A
15 Δ	PISTON CUP	2	AT329	AT329	AT280	AT280	(1) AT329 (1) AT299A
16	ROD ASSEMBLY (pressure models)	2	AT465FZ	AT547BZ	AT467FZ	AT584BZ	(1) AT453FZ (1) AT459QZ
	ROD ASSEMBLY (vacuum models)	2	AT466FVZ	AT560BVZ	AT469FVZ	AT493BVZ	
17	SHROUD	2	AT266	AT266	AT266	AT266	AT266
18	FAN	1	AT260A	AT260A	AT260A	AT260A	AT260A
18A	FAN-LEAD END	1	AT259A	AT259A	AT259A	AT259A	AT259A
19	SHROUD SCREW	8	AT261	AT261	AT261	AT261	AT261
20	VALVE PLATE ASSEMBLY	1	AT633	AT633	AT634	AT634	AT633G
		1	AT633A	AT633A	AT634A	AT634A	AT634X
21	RELIEF VALVE	1					AT471
22	FILTER	1					AT441
***	RUBBER FEET	4	AB319	AB319	AB319	AB319	AB319
***	SERVICE KIT	1	K557	K557	K558	K558	K634

*** Item not shown.

Δ Denotes parts included in the Service Kit.

Parts listed are for stock models. For specific OEM models, please consult the factory.

When corresponding or ordering parts, please give complete model and serial numbers.

TROUBLESHOOTING CHART

Low		High		Pump Overheat	Won't Start	Excess Noise	Reason and remedy for problem.
Vacuum	Pressure	Vacuum	Pressure				
•	•	•		•	•		Filter dirty. Clean or replace.
•	•		•	•	•		Muffler dirty. Clean or replace.
•	•						Valves dirty or valves bent. Clean or replace.
•	•						Worn cup. Repair or replace.
			•	•	•		Relief valve set too high. Inspect and adjust.
•	•						Relief valve set too low. Inspect and adjust.
•	•	•	•	•	•		Plugged vacuum/pressure line. Inspect and repair.
•		•					Collapsed vacuum line. Inspect and repair.
				•	•		Low voltage, won't start. Check power source.
				•	•	•	Voltage wrong. Check power source.
•	•					•	Worn cup/piston hitting cylinder. Replace.
				•		•	Cylinder misadjustment. Realign.
•	•				•		Leaky hose or check valve. Replace.
•	•			•	•	•	Dirt or liquid on top of piston. Inspect and clean.
•	•			•	•	•	Motor not wired correctly. Check wiring diagram/line voltage.
•	•					•	Blown head gasket. Replace.



GAST MANUFACTURING, INC.
 A Unit of DEX Corporation
 Post Office Box 97
 Benton Harbor, Michigan
 Ph: 269/926-6171
 Fax: 269/925-8288

PART NO.

RTD989

REV.

A

NOTES:

1. ALL DIMENSIONS ARE FOR REFERENCE USE ONLY.
2. PRODUCT DIMENSIONS: U.S. IMPERIAL (inches) METRIC (mm).
3. * - TECHNICAL DATA SUBJECT TO CHANGE WITHOUT NOTICE.
4. INSTALLATION: THIS PUMP MUST BE INSTALLED IN AN ENCLOSURE.
5. INCLUDES A K981 ELECTRICAL PARTS KIT.

SOUND LEVEL	Less Than 70 dB(A)
NORMAL AMBIENT	+5 degC - +40 degC
RELATIVE HUMIDITY	20% - 80%
ENVIRONMENT	Clean Dust Free
REGULATORY	cURus, CE

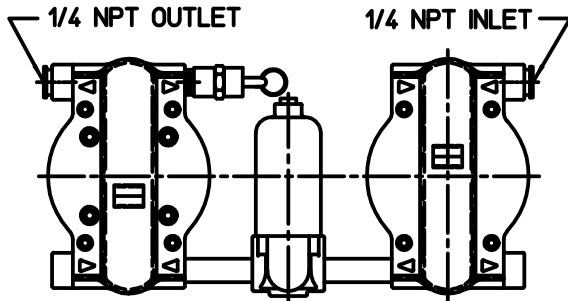

WIRING DIAGRAM

LOW VOLTAGE	HIGH VOLTAGE
BRN — CAP	BRN — CAP
WHT — LINE 1	WHT — LINE 1
BLK — LINE 2	BLU — LINE 2
BLU — INSUL	BLK — INSUL
ORG — INSUL	RED — INSUL
RED — INSUL	ORG — INSUL

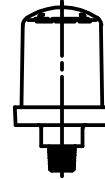

FILTER, UNATTACHED

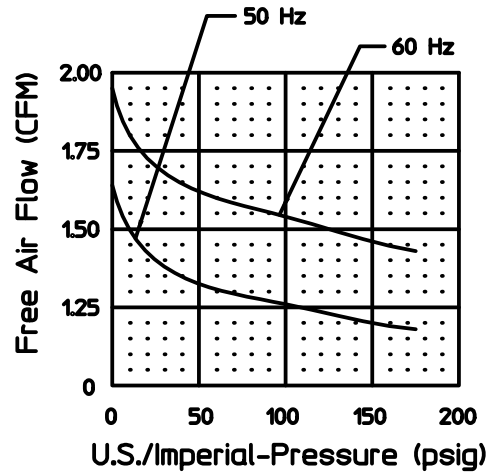
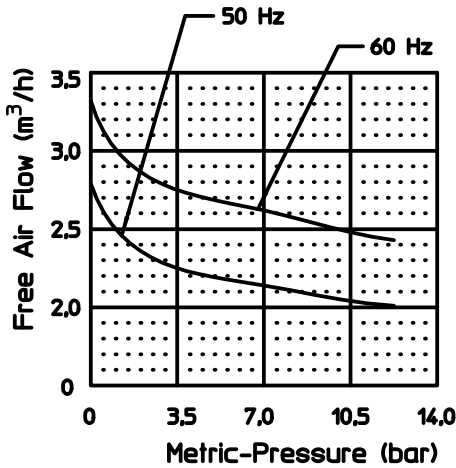
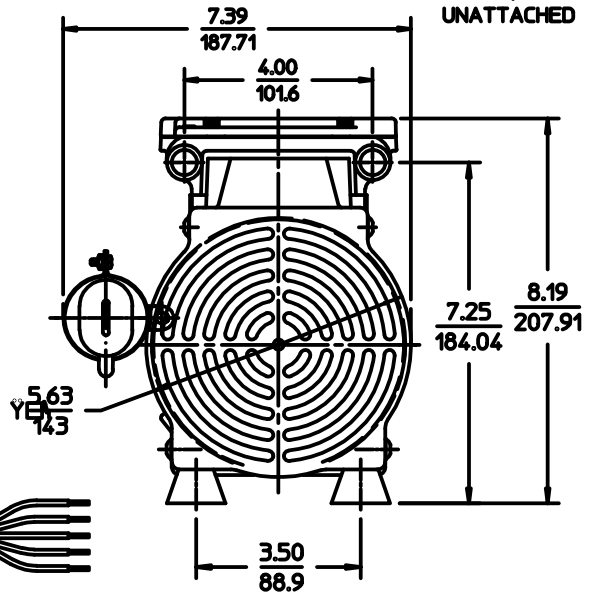
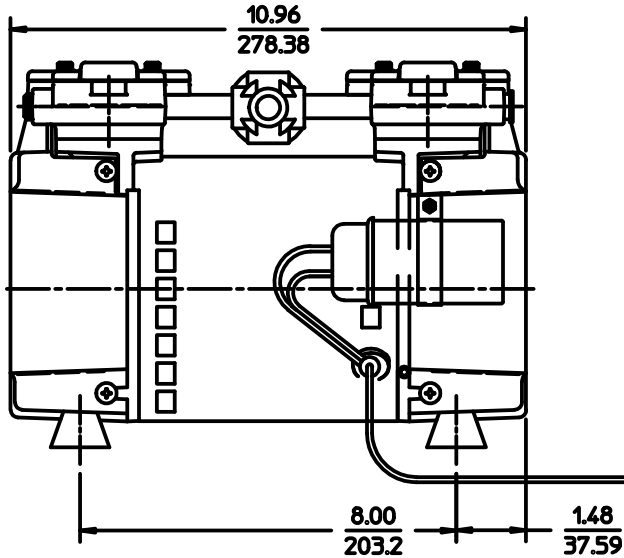

Product Specifications

Model Number	MOTOR VOLTS (SINGLE PHASE ONLY)		HZ.	RPM	HP	kW	Net Wt.		AMPS	CAPACITOR mfd. - volts
	lbs.	kg								
71R545-P315B-N570X	115-120/230-240		60	1725	3/4	.56	16	7.3	5.0/2.6	45 - 370
	110-120/220-240		50	1425	3/4	.56	16	7.3	6.2/3.3	45 - 370

FluidPro™ 100

Membrane Air Dryer

Technical Data Sheet

555727-88-N NPT Fittings
555727-88 BSPT Fittings

SPECIFICATIONS

Component	Material/Value
Shell Material	Anodized aluminum (blue)
End Cap Material	Nylon (black)
Connection	1/4" NPT (1/4" BSPT)
Mounting Orientation	Any
Temperature Range	+35 to 140°F (+2 to 60°C)
Operating Pressure	up to 181.3 psig (12.5 barg)
Requested Particulate Filter	1 µm
Requested Coalescing Filter	0.01 µm
Pressure Drop	0.73 to 5.8 psi (0.05 to 0.4 bar)
Weight	1.46 lbs (0.66 kg)

PERFORMANCE DATA

@102 psi (7 barg), pressure dew point supression from 95°F (35°C) to :								
	59°F (15°C)		37.4°F (3°C)		-4°F (-20°C)		-40°F (-40°C)	
	Inlet	Outlet	Inlet	Outlet	Inlet	Outlet	Inlet	Outlet
Compressed air flow - scfm (Lpm)	3.53 (100)	3.2 (90.5)	2.51 (71.1)	2.18 (61.6)	1.67 (47.3)	1.33 (37.8)	1.21 (34.3)	0.88 (24.8)
Purge air - scfm (Lpm)	0.34 (9.5)							

Purge tolerance +3% of maximum inlet flow range

Dew point supression from 95°F (35°C) at 102 psig (7 barg) to:

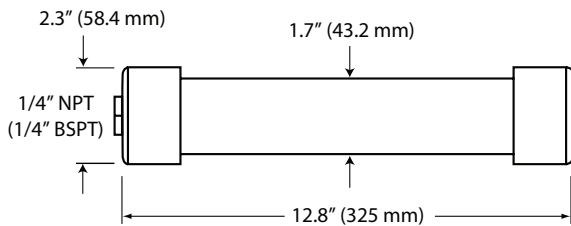
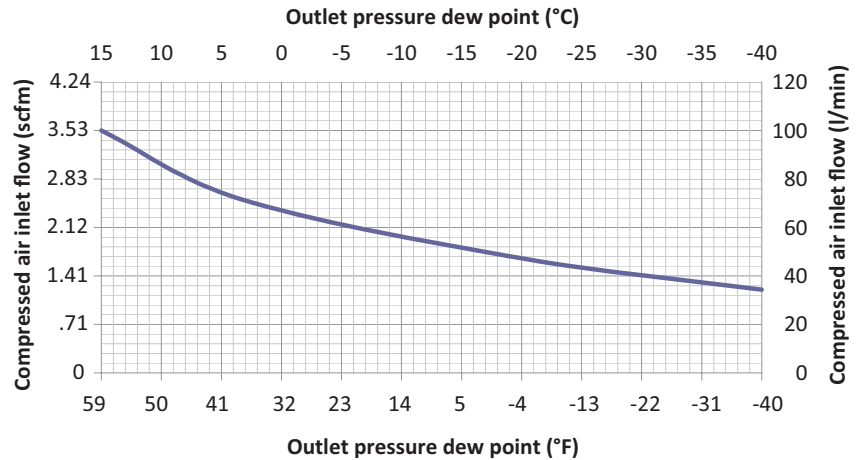

Performance Correction Factors for Different Pressures

For maximum flow rate, multiply flow rate shown in the above table by the correction factor corresponding to the working pressure.

Operating Pressure psig (barg)	58 (4)	73 (5)	87 (6)	102 (7)	116 (8)	131 (9)	145 (10)	160 (11)	174 (12)
Correction Factor	0.41	0.56	0.76	1	1.22	1.48	1.76	1.86	2.22

Disclaimer: Specifications subject to change.





FluidPro™ Installation Guide

Dear customer,

Thank you for choosing the FluidPro™ membrane air dryer for your application. Please read these instructions carefully before you install the dryer and put it into service. The performance of the FluidPro™ membrane air dryer can only be guaranteed if the rules and requirements stated here are complied with.

Pentair Liability:

Warranty for FluidPro™ is 1 year from date of shipment. Pentair will not accept any liability if the following requirements and the instructions for installation are not respected:

- Appropriate pre filtration must be installed upstream the membrane air dryer (1µ particulate and 0,01 µ coalescing)
- The pre-filtration must be maintained on a regular basis (minimum once a year).

Pentair shall not be liable for damage due to improper or incorrect use, wear, storage or other actions by third parties or the purchaser.

Requirements:

Temperature:

There must be no possibility of frost at the place of installation. Both the environmental temperature and compressed air temperature should range from +3°C to +60°C (140°F).

Maximum Pressure:

12.5 barg

Pre-Filtration Required:

1µm particulate filter
0.01 µ coalescing filter
Particulate and oil contamination as well as liquid condensate have to be safely removed and retained before the compressed air flows into the membrane air dryer.

Installation Precautions:

1. FluidPro™ must only be used in industrial applications for compressed air.
2. The compressed air system must be fully depressurized while pneumatic components are being installed.
3. Before installing the piping, be sure to thoroughly flush the inside of the piping with compressed air. Do not let seal tape or other foreign material get inside the piping while installing. Note: Do not use galvanized fittings between this filter and membrane air dryer

4. 1µm air filter and a 0.01 µ coalescing filter must be installed inline, prior to the FluidPro™ membrane air dryer. The Membrane air dryer must be located directly downstream of the 0,01 coalescing filter in order to avoid renewed condensate formation.
5. FluidPro™ air dryers cannot be used if the following substances are incorporated in the air or fluid: Chemicals which may interfere with the performance of this unit include aromatic hydrocarbons, chlorinated or halogenated hydrocarbons, ketones, esters, ozone, strong acids or bases, and phenols. We recommend to use the following sealants: Teflon tape, Loctite 55, Loctite 30561, Loctite 30556, LA-CO Slic-tite, LA-CO Plasto-Joint Stick. **DO NOT USE: Loctite 561, Loctite 565, Loctite 569 and all other anaerobic thread lockers**
6. Ensure that the purge holes of the membrane air dryer (located on the product shell close to the inlet end cap) are clean. Do not use stickers or labels in that area and do not use cleaning agents or solvents around this area either.
7. Flow control devices should be installed downstream from the FluidPro™ membrane air dryer.
8. Ensure air lines to the air dryer and air dryer are aligned in the correct flow direction
9. Turn on compressed air supply slowly.

Note: If maximum flow rate for the membrane air dryer exceeds the published rate, the specified dew point suppression may not be met.

